

LEADER[®] LVL[®]
LEADER VALVES LTD.



Manufacturing Widest Range of Valves & Fittings for All Applications



CAST STEEL



LVL Leading Products 1

LEADER VALVES LTD.

www.leadervalves.com



Sr.	Contents	Pages
1.	Company Profile.....	3
2.	Quality Policy.....	4
3.	Certification.....	5
4.	Interface.....	6
5.	Gate Valve General Description.....	7
6.	Gate Valve Technical & Dimensional Data for CL-150, 300, 600, 1500.....	8-12
7.	Gate Valve Pressure Seal Bonnet CL-900, 1500, 2500.....	13-15
8.	Cast Steel Gate Valve Extended Range.....	16-17
9.	Globe Valve General Description.....	18
10.	Globe Valve Technical & Dimensional Data for CL-150, 300, 600, 1500.....	19-21
11.	Globe Valve Pressure Seal Bonnet CL-900, 1500, 2500.....	22-24
12.	Cast Steel Globe Valve Extended Range.....	25
13.	Globe Valve Technical & Dimensional Date for PN-40.....	26-29
14.	Swing Check Valve Description.....	30
15.	Swing Check Valve Technical & Dimensional Data for CL-150, 300, 600, 1500.....	31-33
16.	Swing Check Valve Pressure Seal Bonnet CL-900, 1500, 2500.....	34-35
17.	Horizontal Check Valve.....	36-37
18.	Ball Valve Description.....	38-39
19.	Ball Valve Technical & Dimensional Date for CL-150, 300, 600.....	40-42
20.	Gland Valve General Description.....	43
21.	Gland less Piston Valve.....	44-45
22.	Lubricated Taper Plug Valve.....	46-47
23.	Dual Plate Check Valve General Description.....	48
24.	Wafer Type Dual Plate Check Valve PN-16 Technical & Dimensional Data....	49-54
25.	Wafer Type Check Valve Description & Technical Data.....	55-56
26.	Butterfly Valve Description & Technical Data for PN-10.....	57-58
27.	Pressure Temperature Rating.....	59-61
28.	Manufacturing Facilities.....	62-63



Company Profile

LEADER VALVES LIMITED is a leading, totally integrated valves manufacturing unit with its own Ferrous & Non Ferrous Foundries and Forging unit in India.

The company was set up more than six decades ago when India was on the threshold of industrial revolution and there were no good valve manufacturers in the country. It has over the years built up an excellent track record by following the policy of customer satisfaction.

We are an ISO-9001:2008 company since Jan. 1996 certified by LRQA, India. The company is licensed to use API Spec 6D (Certificate No. 6D-0346), and API 600 (Certificate No. 600-0018) monograms.

Structural Integrity Division of National Aerospace Laboratory Bangalore has tested and certified our valves for "Seismic Qualification" of bi-directional valves.



Leader Ferrous & Non Ferrous foundries are certified as "Well Known FOUNDRY" Under Indian Boiler Regulation 4C (2) of Central Boiler Board, Govt. of India Besides being PED certified by M/s. LRQA & AD 2000-Merkblatt WO certified by TUV.

The company is managed by an Efficient Board of Directors & well qualified professionals.

Leader High Pressure Fittings (I) Ltd. and Leader Exports are other two Associate Units of Leader Valves Ltd. manufacturing high pressure valves and fittings. We are also doing job work for some of the worlds leading valves manufacturing companies.





QUALITY POLICY

We at Leader Valves Ltd and leader Export want to achieve Customer Satisfaction.

- 1) By meeting the customer stated & implied requirements.
- 2) By meeting the applicable statutory & regulatory requirement.
- 3) Through Continual Improvement in
 - a) Quality Management System.
 - b) Manufacturing Process.
- 4) By adding new designs & improving existing designs for marketing the products which are Competitive , Safe and Harmless to the environment.





CERTIFICATE OF APPROVAL

(This is to certify that the Quality Management System of)

Leader Valves Ltd.
Jalandhar,
INDIA

has been approved by Lloyd's Register Quality Assurance by the following Quality Management System Standard:

BS EN ISO 9001:2008

The Quality Management System is applicable to:

- The design, development and production of ferron valves maximum size of NPS16 (DN50) nominal size, non ferron valves maximum size NPS 24 (DN60) nominal size, ball valves maximum size NPS 12 (DN30) nominal size and forged fittings maximum size NPS 2 (DN50) nominal size.
- The manufacture of ferron castings maximum weight of 2000 kg and non ferron castings maximum weight of 1000 kg.

The certificate is valid only in accordance with the conditions set out in the contract bearing the reference number on which this certificate is issued in the approved schedule.

Notified Certificate No: 0404380001 Original Validity: 25 January 2010
Current Certificate: 01 January 2012 Current Certificate: 01 January 2012
Certificate Expiry: 01 February 2012

Issued by Lloyd's Register Quality Assurance Limited

CERTIFICATE SCHEDULE

Leader Valves Ltd.
Jalandhar,
INDIA

Head Office:
S.S. 5.4 Industrial Town,
Jalandhar - 144 004,
Punjab, India.

Other Locations:
Leader Valves Ltd.
Jalandhar,
Punjab, India.
Leader Valves Ltd.
Jalandhar,
Punjab, India.

Approved Certificate No: 0404380001
Current Certificate: 01 January 2012
Expiry Date: 01 February 2012

Page 1 of 1

Certificate of Authority to use the Official API Monogram

Leader Valves Ltd.
Jalandhar,
INDIA

American Petroleum Institute

(This is to certify that the Quality Management System of)

Leader Valves Ltd.
Jalandhar,
INDIA

has been approved by American Petroleum Institute by the following Quality Management System Standard:

API 603

The Quality Management System is applicable to:

- The design, development and production of ferron valves maximum size NPS 24 (DN60) nominal size, non ferron valves maximum size NPS 12 (DN30) nominal size and forged fittings maximum size NPS 2 (DN50) nominal size.
- The manufacture of ferron castings maximum weight of 2000 kg and non ferron castings maximum weight of 1000 kg.

The certificate is valid only in accordance with the conditions set out in the contract bearing the reference number on which this certificate is issued in the approved schedule.

Notified Certificate No: 0404380001 Original Validity: 25 January 2010
Current Certificate: 01 January 2012 Current Certificate: 01 January 2012
Certificate Expiry: 01 February 2012

Issued by American Petroleum Institute

Lloyd's Register

EC CERTIFICATE OF QUALITY SYSTEM APPROVAL

in accordance with the requirements of the Pressure Equipment Directive 97/23/EC and the Pressure Equipment Regulations 1999, UK Statutory Instrument 1999 No. 2001 and 2002 No. 1267

This is a certificate for the Quality Management System of

Leader Valves Limited
S.S. 5.4 Industrial Town,
Jalandhar 144004
Punjab,
India.

The manufacture of ferron castings up to maximum weight of 2000 kg and non ferron castings up to maximum weight of 1000 kg.

Notified Certificate No: 0404380001 Original Validity: 25 January 2010
Current Certificate: 01 January 2012 Current Certificate: 01 January 2012
Certificate Expiry: 01 February 2012

Issued by Lloyd's Register Quality Assurance Limited

Lloyd's Register

EC CERTIFICATE OF QUALITY SYSTEM APPROVAL
CERTIFICATE 0038/PED/20020246/A SCHEDULE

Leader Valves Limited
S.S. 5.4 Industrial Town,
Jalandhar 144004
Punjab, India.

DESCRIPTION	MATERIAL GRADE	PRODUCTION FORM
Gate Valve	WCB, 20	Cast
Ball Valve	WCB, 20	Cast
Gate Valve	WCB, 20	Cast
Ball Valve	WCB, 20	Cast
Gate Valve	WCB, 20	Cast
Ball Valve	WCB, 20	Cast
Gate Valve	WCB, 20	Cast
Ball Valve	WCB, 20	Cast
Gate Valve	WCB, 20	Cast
Ball Valve	WCB, 20	Cast
Gate Valve	WCB, 20	Cast
Ball Valve	WCB, 20	Cast
Gate Valve	WCB, 20	Cast
Ball Valve	WCB, 20	Cast
Gate Valve	WCB, 20	Cast
Ball Valve	WCB, 20	Cast
Gate Valve	WCB, 20	Cast
Ball Valve	WCB, 20	Cast
Gate Valve	WCB, 20	Cast
Ball Valve	WCB, 20	Cast

Notified Certificate No: 0404380001 Original Validity: 25 January 2010
Current Certificate: 01 January 2012 Current Certificate: 01 January 2012
Certificate Expiry: 01 February 2012

Issued by Lloyd's Register Quality Assurance Limited

TUV NORD

CERTIFICATE
TUV CERT-Certification Body for Pressure Equipment
of TUV NORD Systems GmbH & Co. KG

This certifies that the company

Leader Valves Limited
Ramnagar, Jalandhar - 144 004,
Punjab, India

has been notified and recognized as notified manufacturer according to

AD 2000-Merkblatt W3

Certificate No.: 07 202 1423 WP 1122 08

The scope of validity and details of the inspection can be found in the report No. 0100308

July 2012

Issued by TÜV NORD

FORM XVI-B
[Regulation 4C (2)]

Central Water Board
Certificate of Approval for Well Known Foundry

This is to certify that the Inspection and Quality Management System of:

Leader Valves Limited
S.S. 5.4 Industrial Town,
Jalandhar - 144 004,
Punjab

has been obtained by the Central Water Board and has been granted recognition under regulation 4C (2) of the Indian Water Regulations, 1956, as a WELL KNOWN FOUNDRY FOR MANUFACTURE OF CASTINGS WITH A MAXIMUM OF 1000 KGS PER DAY.

This Certificate is valid for the period of 01/01/2012 to 31/12/2012.

Validity is subject to the adherence to the quality control procedures under the provisions of the Indian Water Regulations, 1956.

16/04/2012
Date of Issue

Approved
Certificate No: 333

CPD

SHRI RAM ENGINEERS
INDIA LIMITED
PUNJAB

Procurement Development Department

This is to certify that the company

Leader Valves Limited
Ramnagar, Jalandhar - 144 004,
Punjab, India

has been notified and recognized as notified manufacturer according to

AD 2000-Merkblatt W3

Certificate No.: 07 202 1423 WP 1122 08

The scope of validity and details of the inspection can be found in the report No. 0100308

July 2012

Issued by SHRI RAM ENGINEERS INDIA LIMITED

SHRI RAM ENGINEERS
INDIA LIMITED
PUNJAB

Procurement Development Department

Cylinder Valve (Gate Valve) Polymed	10" 15"	2000	1500	1500
Gate Valve Polymed	10" 15"	1000	1000	1000

(This statement is valid for your works located at S.S. 5-4 Ind. Town, Jalandhar - 144004)

Please note that this certification is subject to satisfactory evaluation of orders in delivery and quality of above mentioned lots when ordered for our various projects.

Further, it may be noted that any change in the product range, location of Works/Sales Office, Management/ Organization structure etc. shall be intimated to us immediately along with relevant document for our necessary action. In case, information to any of the above referred changes is not intimated timely, our enquiries may not reach you and your entitlement with us is liable to be cancelled. Entitlement with us shall not guarantee any regular flow of enquiries.

The validity of this EMPLIMENT is upto 30th November, 2012.

You are advised to apply on-line for recertification, 6 months before expiry of the statement. Detailed procedure for recertification can be seen on our website www.shriramindia.com

Thanking you.

SHRI RAM ENGINEERS INDIA LIMITED
PUNJAB



API 600 Gate, Globe & Check Valves

Bolted Bonnet/Cover design

The API 600 family of Leader Gate, Globe and Swing Check Valves is exceptionally sturdy, rugged and durable, with a reputation for quality, integrity and long service. They are designed for tight sealing and ease of operation. The valves are available with flanged ends or butt-ends, in pressure ratings from ASME Class 150 and in a variety of materials of construction.

Gate Valves are of flexible/solid wedge, outside screw-and-yoke and bolted-bonnet construction. The valves conform to API 600/BS1414.

Globe Valves feature a ball-type disc, outside screw-and-yoke and bolted-bonnet construction. They conform to BS 1873 and also meet the general requirements of API 600, including wall thickness and stuffing box dimensions.

Check Valves are of swing-type and bolted-cover construction. They conform to BS 1868/API 6D and also meet the general requirement of API 600, including wall thickness.

Body and Bonnet:

The body and bonnet are cast with uniform section and generous radius fillets to prevent stress concentration. The castings are precision-machined for high performance & surface finish.

The gate valve body has a straight through port without recesses except at the seat area. This ensures minimum turbulence, erosion and resistance to flow. Long integral guide ribs in the body match with guide slots in the wedge for accurate alignment and guidance. Bonnet castings are of one-piece design, where the yoke is integral with the bonnet for gate valves of sizes up to 12" (300mm). This ensures accurate alignment of stem and a smooth operation.

In globe valves of larger sizes and for higher pressure classes of ASME Class 900 and above, the internal part of the body is machined to provide continuous

guiding of the disc from the open to the closed position. The check valve body provides a full port without pockets form inlet to the valve seat. On the downstream side, the body has generous proportions to facilitate full swing of the disc to reduce disc erosion and flow resistance.

Body-Bonnet Joint:

The body-bonnet joint for Class 150 gate valves is oval in Class 300 and for globe valves, this joint is circular in shape. In 2" (50mm) valve, the body-bonnet joint has a square configuration.

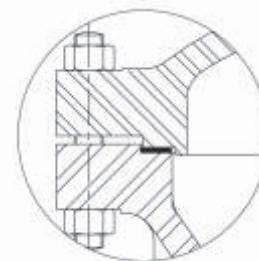

BODY-BONNET JOINT

Gate valves of Class 150 rating have a flat-face joint with a graphite gasket having metallic inserts. Those of Class 300 rating have a lip type joint with a spirally-wound gasket. Gate valves of Class 600 rating and above have also Ring Type Joint (RTJ)

Globe and Check valve in Class 150 and 300 rating have a male-female type joint with a spirally-wound gasket. Those of class 600 rating and above have an RTJ.

Back Seat:

In All gate and globe valves, a precision-machined back-seat bush is threaded in the bonnet and is secured by a tack-weld.

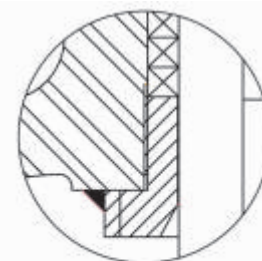

BACK SEAT

Flexible Wedge/Solid

Gate valve feature a one-piece cast flexible wedge that minimises stress concentration. Wedge flexibility ensures tight seating over a wide range of differential pressures and temperatures. It also adjusts to slight misalignments caused by piping deflections and thermal deformation. The stem-to-wedge as applied close to the wedge centre. This reduces lateral stem loading and provides for more accurate wedge movement. Solid Wedge is also provided.

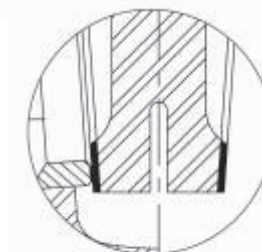

WEDGE



General Description

GATE VALVE

Gate Valve is one of the most common valves used in liquid piping. This valve, as a rule, is an isolation valve used to on and shut off the flow, isolating either a piece of equipment or a pipeline, as opposed to actually regulating flow. The gate valve has a gate-like disc which operates at a right angle to the flow path. As such, it has a straight through port that results in minimum turbulence erosion and resistance to flow. However, because the gate or the seating is perpendicular to the flow, gate valves are impractical for throttling service and are not used for frequent operation applications.

Repeated closure of a gate valve, or rather movement toward closure of a gate valve, results

in high velocity flow. This creates the threat of wire drawing and erosion of seating services. Many gate valves have wedge discs with matching tapered seats. Therefore, the refacing or repairing of the seating surfaces is not a simple operation. Gate valves should not, therefore, be used frequently to avoid increased maintenance costs. In addition, a slightly open gate valve can cause turbulent flow with vibrating and chattering of the disc.

A gate valve usually requires multiple turns of its hand wheel manual operator in order to be opened fully. the volume of flow through the value is not in direct proportion to the number of turns of the hand wheel.



**CAST STEEL
GATE VALVES-
API 600/BS 1414,
Bolted Bonnet
OS & Yoke Type
Rising Stem,
Flanged/Butt
Weld Ends**

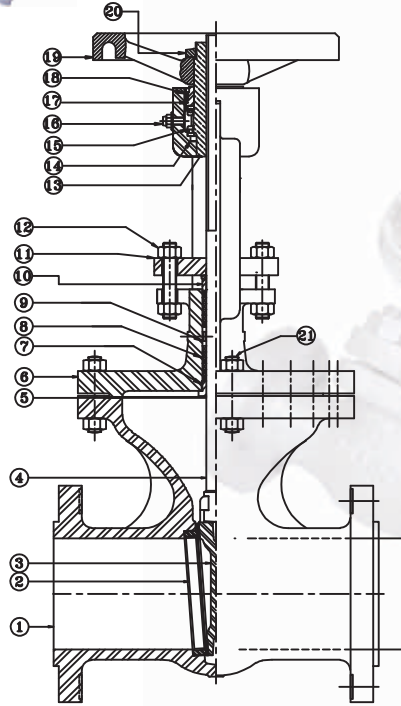

STANDARD MATERIAL COMBINATION

P. NO.	PART DESCRIPTION	Carbon steel to ASTM		Alloy steel to ASTM					Stainless steel to ASTM			
		Type WCB	Type LCB	Type WC1	Type WC6	Type WC9	Type C5	Type C12	Type CF8	Type CF8M	Type CF3	Type CF3M
1	BODY	A216 WCB	A352 LCB	A217 WC1	A217 WC6	A217 WC9	A217 C5	A217 C12	A351 CF8	A351 CF8M	A351 CF3	A351 CF3M
2	Seat Ring	As per Trim Material Combination										
3	Wedge	As per Trim Material Combination										
4	Stem	As per Trim Material Combination										
5	GASKET	Stainless steel + Graphoil										
6	BONNET	A216 WCB	A352 LCB	A217 WC1	A217 WC6	A217 WC9	A217 C5	A217 C12	A351 CF8	A351 CF8M	A351 CF3	A351 CF3M
7	Back Seat Bush	As per Trim Material Combination										
8	PACKING	To Suit Service conditions										
9	Lantern Ring	As per Trim Material Combination										
10	GLAND	A182 F6a	A182 F304	A182 F6a	A182 F6a	A182 F6a	A182 F6a	A182 F6a	F-304	F-316	F-304L	F-316L
11	GLAND FLANGE	A216 WCB	A352 LCB	A217 WC1	A217 WC6	A217 WC9	A217 C5	A217 C12	A351 CF8	A351CF8M	A351 CF3	A351CF3M
12	NUTS	A194 2H	A194 Gr.4	A194 Gr.4	A194 Gr.4	A194 Gr.4	A194 Gr.4	A194 Gr.4	A194 Gr.8	A194 Gr.8	A194 Gr.8	A194 Gr.8
13	YOKE SLEEVE	AI. Bronze BS1982 CC331G or Ni - resist to A439 D2										
14	OIL SEAL	EPDM/BUNA 'N' RUBBER										
15	THRUST BEARING	STEEL										
16	LUBRICATOR	STEEL										
17	YOKE SLEEVE RETAINING NUT	STEEL IS:2062										
18	LOCKING SCREW	STEEL IS:2062										
19	HANDWHEEL	D1 A536 80-55-D6 OR MI 1S 2108 BM 290/ASTMA338										
20	HANDWHEEL RETAINING NUT	STEEL IS:2062										
21	STUDS	A193 B7	A320 L7	A193 B16	A193 B16	A193 B16	A193 B16	A193 B16	A193 B8	A193 B8	A193 B8	A193 B8

NOTE: The above data is subject to change without notice due to our continuing product improvement program.



CAST STEEL GATE VALVES-API 600/BS 1414

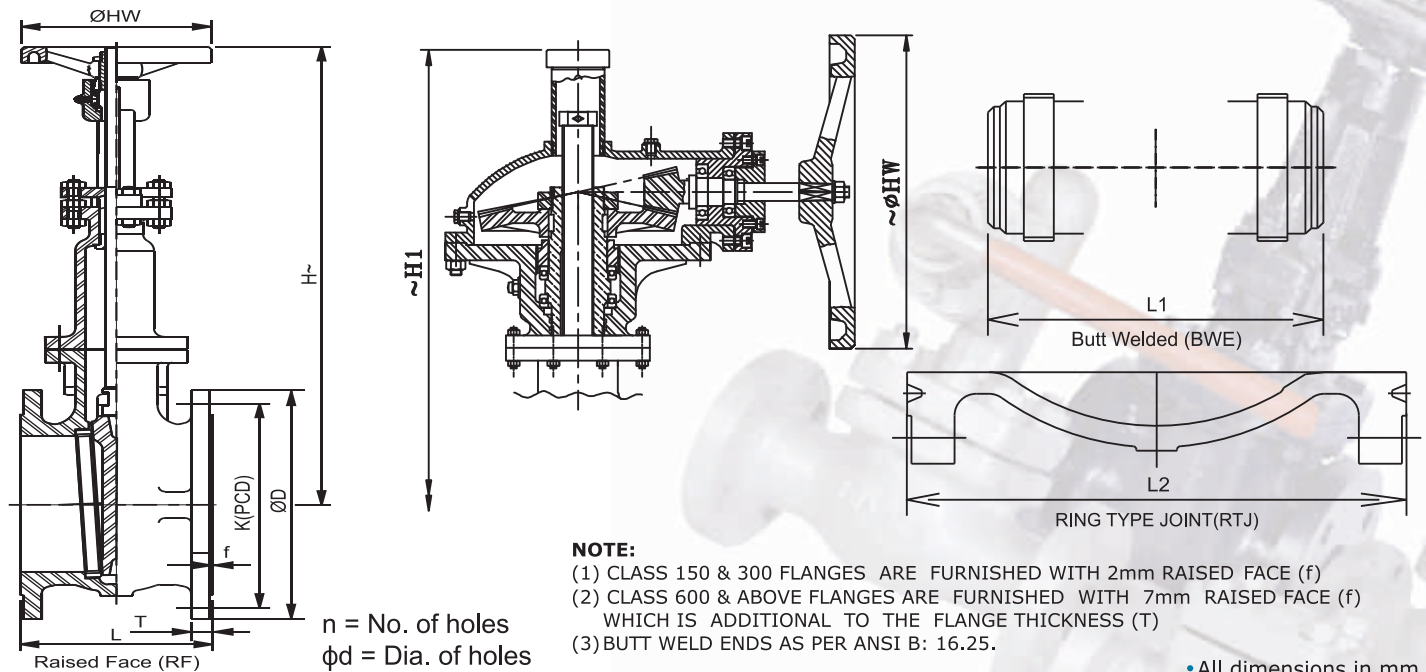

TRIM MATERIAL COMBINATION (ON REQUEST)

Trim No.	Seat Ring Face	Wedge Seat Face	Stem	Backseat Bush	Lantern Ring
1	F6a/13%Cr.	F6a/13%Cr.	F6a/AISI410	F6a/AISI410	F6a/AISI410
2	F304	F304	F304/AISI304	F304/AISI304	F304/AISI304
5	STELLITE	STELLITE	F6a/AISI410	F6a/AISI410	F6a/AISI410
8	STELLITE	F6a/13%Cr.	F6a/AISI410	F6a/AISI410	F6a/AISI410
9	MONEL	MONEL	MONEL	MONEL	MONEL
10	F316	F316	F316/AISI316	F316/AISI316	F316/AISI316
12	316+STELLITE	316	F316/AISI316	F316/AISI316	F316/AISI316
13	ALLOY 20	ALLOY 20	ALLOY 20	ALLOY 20	ALLOY 20

DIMENSIONAL DATA CLASS-150

DN	40	50	65	80	100	125	150	200	250	300*	350*	400*	450*	500*	550*	600*	650*	700*	750*	900*	1000*	1050*
NPS	1 1/2"	2"	2 1/2"	3"	4"	5"	6"	8"	10"	12"	14"	16"	18"	20"	22"	24"	26"	28"	30"	36"	40"	42"
L	165	178	190	203	229	254	267	292	330	356	381	407	432	457	508	508	559	609.6	609.6	711	874	914
L1	165	216	241	282	305	381	403	419	457	502	572	610	660	711	762	813	--	--	--	--	--	--
L2	178	191	230	216	242	267	280	305	343	369	394	420	445	470	521	521	--	--	--	--	--	--
øD	125	150	180	190	230	255	280	245	405	485	535	595	635	700	748.3	815	786	836.6	984.3	1057	1067	1090
T	12.7	14.3	15.9	17.5	22.3	22.3	23.9	27	28.6	30.2	33.4	35	38.1	41.3	45	46.1	41.1	45.5	74.7	75.4	-	-
K(PCD)	98.4	120.6	139.7	152.4	190.5	215.9	241.3	298.4	362	431.8	476.2	539.8	577.8	635	692.1	749.3	744.5	795.3	914.4	1009.7	-	-
n	04	04	04	04	08	08	08	08	12	12	12	16	16	20	20	20	36	40	28	44	-	-
ød	15.9	19	19	19	19	22.2	22.2	22.2	25.4	25.4	28.6	28.6	31.8	31.8	34.9	34.9	22.4	22.3	35.1	25.4	-	-
~H (Close)	326	335	365	370	450	555	596	746	915	-	-	-	-	-	-	-	-	-	-	-	-	-
~H (Open)	366	385	430	450	550	680	746	946	1165	-	-	-	-	-	-	-	-	-	-	-	-	-
~H1	-	-	-	-	-	-	-	-	-	1110	1750	1865	1935	2166	2380	2762	2867	3056	3230	3469	3708	4120
ØHW	210	210	210	235	255	310	310	400	460	500	450	450	450	450	450	450	450	450	450	700	-	-
Aprox.wt. ^	16.6	20	28	32.5	51.2	74	85	136	189	289	467	620	738	970	1045	1290	1513	1735	1910	2528	-	-

*For Gear Operated Valves

NOTE: The above data is subject to change without notice due to our continuing product improvement program. (^WEIGHT GIVEN IN KGS)
 Flanges upto 24" as per ASME B16.5 & above 24" as per ASME B16.47 series A or B.



CAST STEEL GATE VALVES-API 600

•All dimensions in mm

DIMENSIONAL DATA CLASS-300

DN	40	50	65	80	100	125	150	200	250	300*	350*	400*	450*	500*	600*	650*	750*	900*
NPS	1 ½"	2"	2½"	3"	4"	5"	6"	8"	10"	12"	14"	16"	18"	20"	24"	26"	30"	36"
L	190	216	241	282	305	381	403	419	457	502	762	838	914	991	1143	1245	1397	1727
L1	190	216	241	282	305	381	403	419	457	502	762	838	914	991	1143	----	----	----
L2	204	232	257	296	321	397	419	435	473	518	778	854	930	1010	1165	1270	1422	1755
φD	155	165	190	210	255	280	320	380	445	520	585	650	710	775	915	867	990.6	1270
T	19.1	20.7	23.9	27	30.2	33.4	35	39.7	46.1	49.3	54.4	55.6	58.8	62	68.3	89	93.7	104.6
K(PCD)	114.3	127	149.2	168.3	200	235	269.9	330.2	387.4	450.8	514.4	571.5	628.7	685.8	812.8	803.2	920.8	1168.4
n	04	08	08	08	08	08	12	12	16	16	20	20	24	24	24	32	36	36
φd	22.2	19	22.2	22.2	22.2	22.2	22.2	25.4	28.6	31.8	31.8	35	35	35	41	35	38.1	53.8
~H(Close)	357	382	416	432	520	760	746	919	1169	-	-	-	-	-	--	-	-	-
~H (Open)	397	432	481	512	620	885	896	1119	1419	-	-	-	-	-	-	-	-	-
~H1	-	-	-	-	-	-	-	-	-	1237	1915	2000	2146	2760	3125	-	-	4450
φHW	210	210	210	225	310	310	400	450	450	450	-	-	-	-	-	-	-	-
Aprox.wt. ^	24.5	29	47.1	55	80.5	161.6	167.6	263	458	610	920	1056	1145	2055	2730	-	-	-

DIMENSIONAL DATA CLASS-600

DN	40	50	65	80	100	125	150	200	250	300*	350*	400*	450*	500*	600*
NPS	1 ½"	2"	2 ½"	3"	4"	5"	6"	8"	10"	12"	14"	16"	18"	20"	24"
L	241	292	330	356	432	508	559	660	787	838	889	99	1092	1194	1397
L1	241	292	330	356	432	508	559	660	787	838	889	99	1092	1194	1397
L2	241	295	333	359	235	511	562	663	790	841	890	993	1095	1200	1407
φD	155	165	190	210	275	330	355	420	510	560	605	685	745	815	940
T	22.7	25.4	28.6	31.8	38.1	44.5	47.7	55.6	63.5	66.7	69.9	76.2	82.6	88.9	101.6
K(PCD)	114.3	127	149.3	168.1	216	266.7	292.1	349.2	431.8	489	527	603.2	654	724	838.2
n	04	08	08	08	08	08	12	12	16	20	20	20	20	24	24
φd	22.2	19	22.2	22.2	25.4	28.6	28.6	31.8	34.9	34.9	38.1	41.1	44.5	44.5	50.8
~H(Close)	350	427	477	537	623	750	890	978	1040	-	-	-	-	-	-
~H(Open)	390	477	542	617	723	875	1040	1178	1290	-	-	-	-	-	-
~H1	-	-	-	-	-	-	-	-	-	-	1725	2100	2155	2810	3257
φHW	229	229	229	254	356	406	508	508	610	450	450	450	700	700	700
Aprox.wt. ^	32.9	46	75	80	153	264	298.5	593	677	1015	1321	1760	2415	2920	4400

***For Gear Operated Valves**

NOTE: The above data is subject to change without notice due to our continuing product improvement program. (^WEIGHT GIVEN IN KGS)

Flanges upto 24" as per ASME 16.5 and above 24" as per ASME 16.47 series A or B.



•All dimensions in mm

DIMENSIONAL DATA CLASS-900

DN	50	80	100	150*	200*	250*	300*	350*	400*	450*	500*	600*
NPS	2	3	4	6	8	10	12	14	16	18	20	24
L	368	381	457	610	737	838	965	1029	1130	1219	1321	1568
L1	368	381	457	610	737	838	965	1029	1130	1219	1321	1568
L2	371	421	473	549	711	841	968	1039	1140	1232	1334	1587
φD	215	240	290	380	470	545	610	640	705	787	855	1040
T	38.1	38.1	44.5	55.6	63.5	69.9	79.4	85.8	88.9	101.6	108	139.7
K (PCD)	165.1	190.5	234.5	317.5	393.7	469.9	533.4	558.8	615.9	685.8	749.3	901.7
n	08	08	08	12	12	16	20	20	20	20	20	20
φd	25.4	25.4	31.8	31.8	38.1	38.1	38.1	41.3	44.5	50.6	54	66.7
~H(Close)(H1)	480	595	665	1321	1530	1780	1885	2030	2400	2589	2858	3532
~H(Open)	530	675	765	-	-	-	-	-	-	-	-	-
φHW	300	300	400	450	700	700	700	700	700	1000	1000	1000
Aprox.wt. ⤴	88	182	275	478	710	810	1330	1937.36	2710	-	-	7789

DIMENSIONAL DATA CLASS-1500

DN	50	65	80*	100*	150*	200*	250*	300*
NPS	2	2 ½	3	4	6	8	10	12
L	368	419	470	546	705	832	991	1130
L1	368	419	470	546	705	832	991	1130
L2	371	421	473	549	711	842	1001	1146
φD	215	245	265	310	395	485	585	675
T	38.1	41.3	47.7	54	82.6	92.1	108	123.9
K (PCD)	165.1	190	203.2	241.3	317.5	393.7	482.6	571.5
n	08	08	08	08	12	12	12	16
φd	25.4	28.6	31.8	35	38.1	44.5	50.8	54
~H(Close)(H1)	478	550	600	720	1144	1265	1385	1503
~H(Open)	528	615	-	-	-	-	-	-
φHW	300	350	400	450	700	700	700	700
Aprox.wt. ⤴	93	140	173.5	327	633.81	1218	2405	3065

***For Gear Operated Valves**

NOTE: The above data is subject to change without notice due to our continuing product improvement program. (⤴WEIGHT GIVEN IN KGS)

Flanges upto 24" as per ASME 16.5 and above 24" as per ASME 16.47 series A or B.

TEST PRESSURES

CLASS	SHELL TEST (HYDROSTATIC)		SEAT TEST			
			HYDROSTATIC		PNEUMATIC	
150	30 Bar	435 Psi g	22 Bar	319 Psi g	6.9 bar	100 Psi g
300	77 Bar	1102 Psi g	57 Bar	780 Psi g	6.9 bar	100 Psi g
600	154 Bar	2175 Psi g	113 Bar	1595 Psi g	6.9 bar	100 Psi g
900	230 Bar	3350 Psi g	169 Bar	2451 Psi g	6.9 bar	100 Psi g
1500	384 Bar	5568 Psi g	282 Bar	4075 Psi g	6.9 bar	100 Psi g

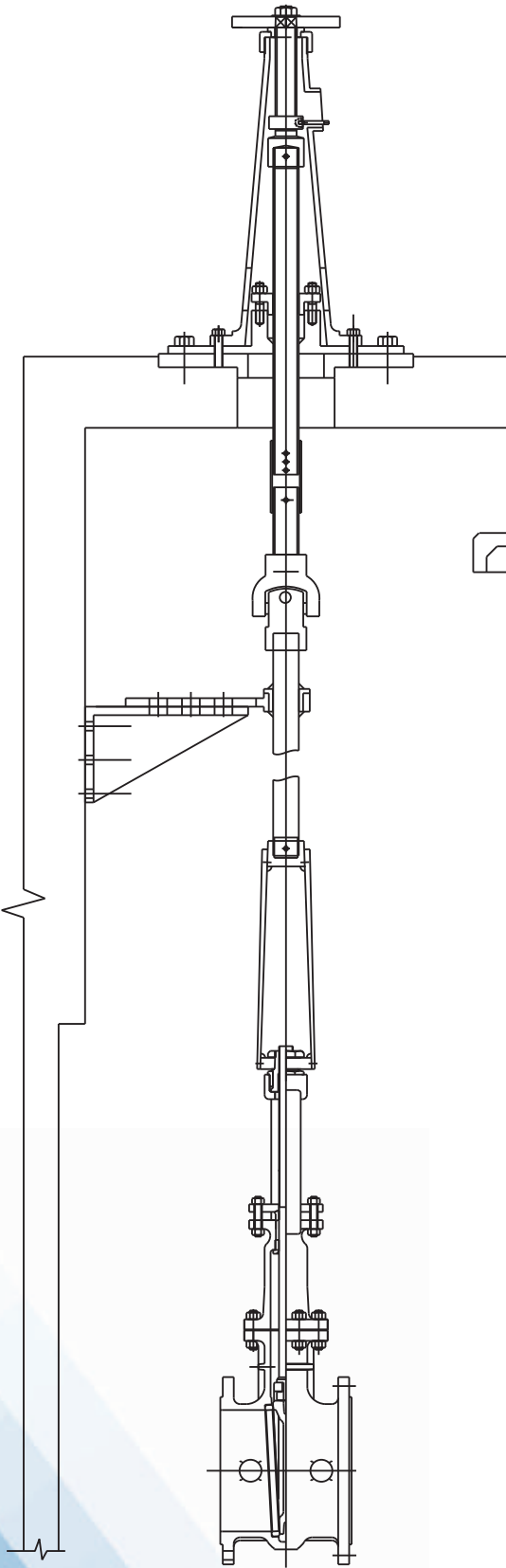

WITH FLOOR STAND

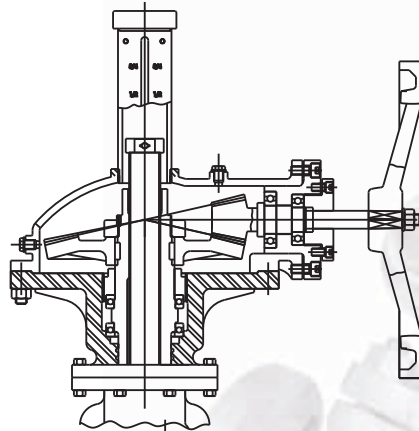

**WITH ENCLOSED TYPE BEVEL
GEAR ARRANGEMENT**

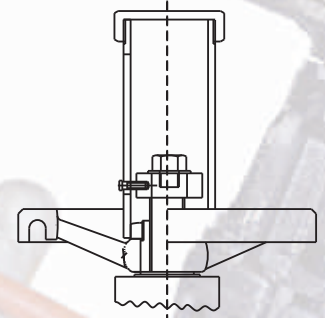

WITH OPEN SHUT INDICATOR

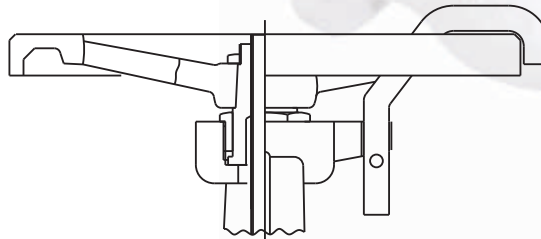

WITH LOCKING

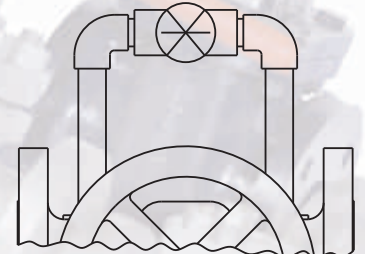

**WITH BY PASS VALVE
ARRANGEMENT**

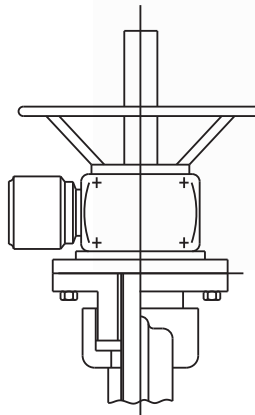

WITH ACTUATOR

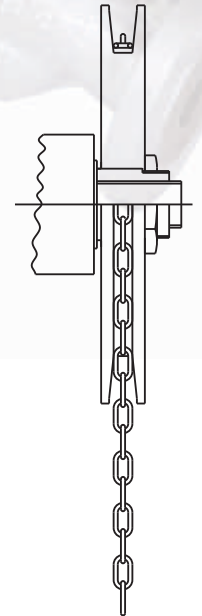

WITH CHAIN-WHEEL

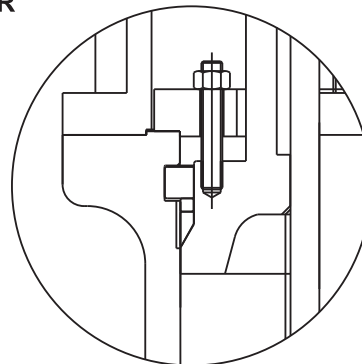

PRESSURE SEAL BONNET

VALVE WITH EXTENDED BONNET (LOW TEMP. SERVICE) CAN ALSO BE SUPPLIED.



**CAST STEEL
GATE VALVES
ASME B 16.34
PRESSURE SEAL
BONNET
OS & YOKE TYPE
RISING STEM,
BUTT WELD/
FLANGED ENDS**

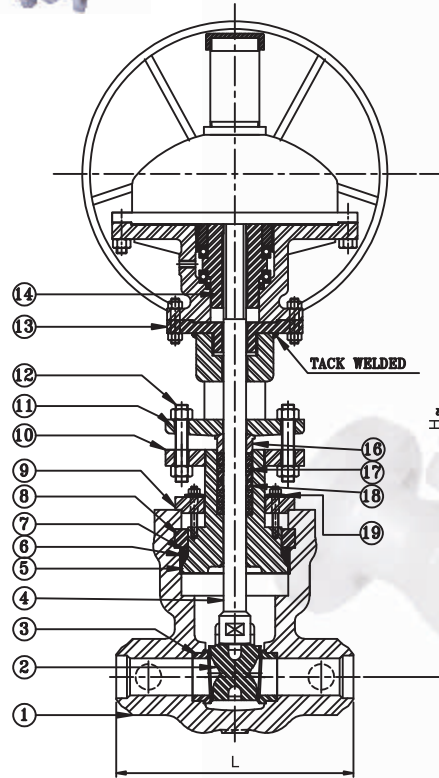

STANDARD MATERIAL COMBINATION

P. NO.	PART DESCRIPTION	Carbon steel to ASTM		Alloy steel to ASTM					Stainless steel to ASTM				
		Type WCB	Type LCB	Type WC1	Type WC6	Type WC9	Type C5	Type C12	Type CF8	Type CF8M	Type CF3	Type CF3M	
1	BODY	A216 WCB	A352 LCB	A217 WC1	A217 WC6	A217 WC9	A217 C5	A217 C12	A351 CF8	A351 CF8M	A351 CF3	A351 CF3M	
2	WEDGE	As per Trim Material Combination											
3	SEAT RING	As per Trim Material Combination											
4	STEM	As per Trim Material Combination											
5	BONNET	A216 WCB	A352 LCB	A217 WC1	A217 WC6	A217 WC9	A217 C5	A217 C12	A351 CF8	A351 CF8M	A351 CF3	A351 CF3M	
6	PRESSURE SEAL GASKET	Graphoil											
7.	Pressure Seal Ring	A182 F6a	A182 F304	A182 F6a	A182 F6a	A182 F6a	A182 F6a	A182 F6a	F-304	F-316	F-304L	F-316L	
8.	Seagmented Ring	A216 WCB	A352 LCB	A217 WC1	A217 WC6	A217 WC9	A217 C5	A217 C12	A351 CF8	A351 CF8M	A351 CF3	A351 CF3M	
9	BONNET RETAINER PLATE	A216 WCB	A352 LCB	A217 WC1	A217 WC6	A217 WC9	A217 C5	A217 C12	A351 CF8	A351CF8M	A351 CF3	A351CF3M	
10	CLAMP	A216 WCB	A352 LCB	A217 WC1	A217 WC6	A217 WC9	A217 C5	A217 C12	A351 CF8	A351 CF8M	A351 CF3	A351 CF3M	
11	GLAND FLANGE	A216 WCB	A352 LCB	A217 WC1	A217 WC6	A217 WC9	A217 C5	A217 C12	A351 CF8	A351CF8M	A351 CF3	A351CF3M	
12	STUD & NUTS	A194 2H	A194 Gr.4	A194 Gr.4	A194 Gr.4	A194 Gr.4	A194 Gr.4	A194 Gr.4	A194 Gr.8	A194 Gr.8	A194 Gr.8	A194 Gr.8	
13	MOUNTING GEAR PLATE	A216 WCB	A352 LCB	A217 WC1	A217 WC6	A217 WC9	A217 C5	A217 C12	A351 CF8	A351CF8M	A351 CF3	A351CF3M	
14	YOKE SLEEVE	AI. Bronze BS1982 CC333G or Ni - resist to A439 D2											
15	THRUST BEARING	STEEL											
16	GLAND	A182 F6a	A182 F304	A182 F6a	A182 F6a	A182 F6a	A182 F6a	A182 F6a	F-304	F-316	F-304L	F-316L	
17	PACKING	To Suit Service conditions											
18	LOCKING SCREW						STEEL			IS:2062			
19	BELLEVILLE WASHER						STEEL			IS:2062			

NOTE: The above data is subject to change without notice due to our continuing product improvement program.



CAST STEEL GATE VALVES PRESSURE SEAL BONNET ASME B16.34

TRIM MATERIAL COMBINATION (ON REQUEST)

Trim No.	Seat Ring Face	Wedge Seat Face	Stem	Backseat Bush	Lantern Ring
1	F6a/13%Cr.	F6a/13%Cr.	F6a/AISI410	F6a/AISI410	F6a/AISI410
2	F304	F304	F304/AISI304	F304/AISI304	F304/AISI304
5	STELLITE	STELLITE	F6a/AISI410	F6a/AISI410	F6a/AISI410
8	STELLITE	F6a/13%Cr.	F6a/AISI410	F6a/AISI410	F6a/AISI410
9	MONEL	MONEL	MONEL	MONEL	MONEL
10	F316	F316	F316/AISI316	F316/AISI316	F316/AISI316
12	316+STELLITE	316	F316/AISI316	F316/AISI316	F316/AISI316
13	ALLOY 20	ALLOY 20	ALLOY 20	ALLOY 20	ALLOY 20

NOTE: Other Trim Combination of API 600 Can Be Provided on Request. Lantern Ring Can Be Provided If Required.

Flanges as per ASME B16.5. Butt Weld Ends as per ANSI B 16.25.

DIMENSIONAL DATA CLASS-900

•All dimensions in mm

DN	50	80	100	150*	200*	250*	300*	350*	400*	450*	500*	600*
NPS	2	3	4	6	8	10	12	14	16	18	20	24
L	368	381	457	610	737	838	965	1029	1130	1219	1321	1568
L1	368	381	457	610	737	838	965	1029	1130	1219	1321	1568
L2	371	421	473	549	711	841	968	1039	1140	1232	1334	1587
φD	215	240	290	380	470	545	610	640	705	787	855	1040
T	38.1	38.1	44.5	55.6	63.5	69.9	79.4	85.8	88.9	101.6	108	139.7
K (PCD)	165.1	190.5	234.5	317.5	393.7	469.9	533.4	558.8	615.9	685.8	749.3	901.7
n	08	08	08	12	12	16	20	20	20	20	20	20
φd	25.4	25.4	31.8	31.8	38.1	38.1	38.1	41.3	44.5	50.6	54	66.7
~H(Close)(H1)	480	595	665	1321	1530	1780	1885	2030	2400	2589	2858	3532
~H(Open)	530	675	765	-	-	-	-	-	-	-	-	-
φHW	300	300	400	450	700	700	700	700	700	1000	1000	1000
Aprox.wt. ▲	88	182	275	478	710	810	1330	1937.36	2710	-	-	7789

DIMENSIONAL DATA CLASS-1500

DN	50	65	80*	100*	150*	200*	250*	300*
NPS	2	2 ½	3	4	6	8	10	12
L	368	419	470	546	705	832	991	1130
L1	368	419	470	546	705	832	991	1130
L2	371	421	473	549	711	842	1001	1146
φD	215	245	265	310	395	485	585	675
T	38.1	41.3	47.8	54	82.6	92.1	108	123.9
K (PCD)	165.1	190	203.2	241.3	317.5	393.7	482.6	571.5
n	08	08	08	08	12	12	12	16
φd	25.4	28.6	31.8	35	38.1	44.5	50.8	54
~H(Close)(H1)	478	550	600	720	1144	1265	1385	1503
~H(Open)	528	615	-	-	-	-	-	-
φHW	300	350	400	450	700	700	700	700
Aprox.wt. ▲	93	140	173.5	327	633.81	1218	2405	3065



CAST STEEL GATE VALVES PRESSURE SEAL BONNET ASME B16.34

DIMENSIONAL DATA CLASS-2500

DN	50	80*	100*	150*	200*	250*	300*
NPS	2	3	4	6	8	10	12
L	451	578	673	914	1022	1270	1422
L1	451	578	673	914	1022	1270	1422
L2	454	584	684	928	1038	1292	1445
φD	235	305	355	485	550	675	760
T	50.9	66.7	76.2	108	127	165.1	184.2
K(PCD)	171.5	228.6	273	368.3	438.2	539.8	619.2
n	08	08	08	08	12	12	12
φd	28.6	35	41.3	53.9	53.8	66.5	73.2
~H(Close)(H1)	357	500	530	670	730	810	970
~H(Open)	407	-	-	-	-	-	-
φb	38	57	73	111	146	184	219
Aprox.wt. ^	110.7	217.2	340.5	637	1097	1865	2767

***For Gear Operated Valves**

NOTE: The above data is subject to change without notice due to our continuing product improvement program. (^WEIGHT GIVEN IN KGS)

Flanges upto 24" as per ASME 16.5 and above 24" as per ASME 16.47 series A or B. H1 for gear operated valves.

TEST PRESSURES

CLASS	SHELL TEST (HYDROSTATIC)					
900	230 Bar	3350 Psi g	169 Bar	2451 Psi g	6.9 bar	100 Psi g
1500	384 Bar	5568 Psi g	282 Bar	4075 Psi g	6.9 bar	100 Psi g
2500	639 Bar	9372 Psi g	469 Bar	6785 Psi g	6.9 bar	100 Psi g

NOTE: The above data is subject to change without notice due to our continuing product improvement program.

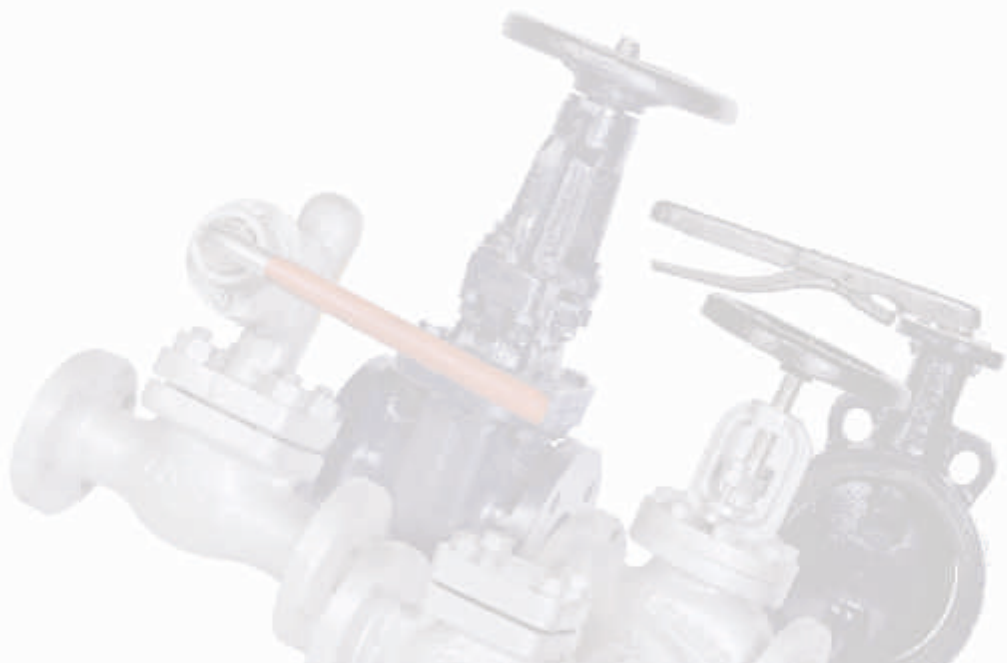



CAST STEEL PARALLEL SLIDE GATE VALVES

Features and benefits

- Self cleaning action between disk & seat
Welded in seats hard faced with Stellite or Equivalent.
- Low cost Maintenance
Lower operating forces than wedge gate design.
- Lower Pressure drop characteristic than wedge gate valve.
- Minimised flow turbulence
- Improved sealing assisted by line pressure.

Typical Applications

- Spray Water
- Blow Off Service
- Blow Down Service
- H.P. Feed Heater Isolation & By-Pass
- Main Steam Isolation
- Boiler Feed Pump Isolation
- Steam Turbine Inlet Isolation

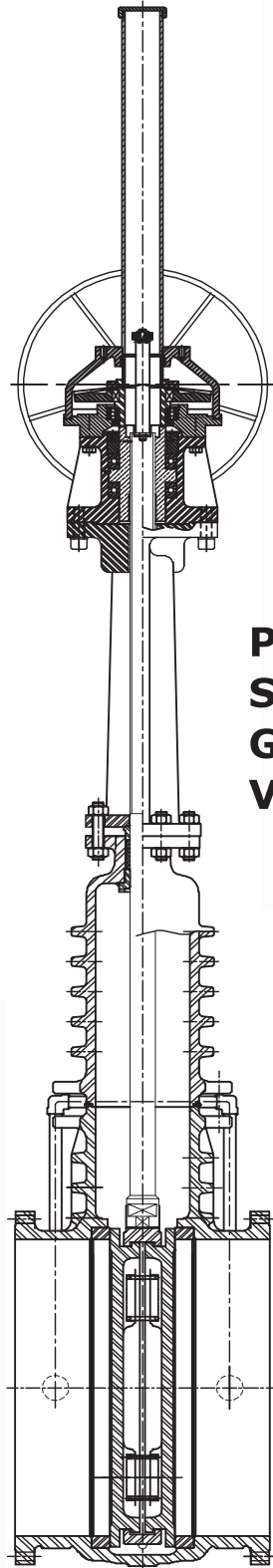

**Parallel
Slide
Gate
Valve**





CAST STEEL LOW TEMPERATURE CRYOGENIC GATE VALVES API 600, BS: 6364, EXTENDED BONNET

Features and benefits

- Adapted to Special Service
- Extended bonnets with sufficient gas column length, are supplied for all valves to keep stem packing at sufficient distance away from the cold fluid to remain functional.
- Flexible wedges with Stellite seating faces for cryogenic service.
- Cleaning: All cryogenic valves are thoroughly degreased and cleaned and pipe ends are sealed to prevent contamination.

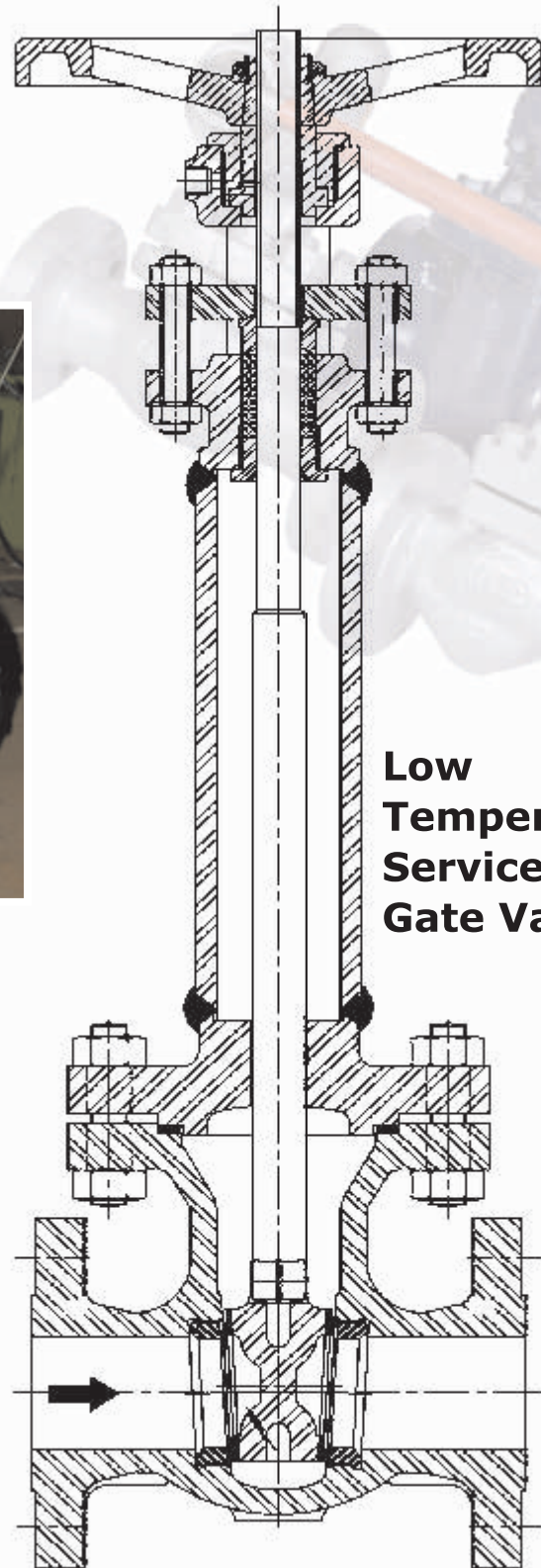

**Low
Temperature
Service
Gate Valve**



General Description

CAST STEEL GLOBE VALVE

Liquid flow does not pass straight through globe valves. Therefore, it causes an increased resistance to flow and a considerable pressure drop. Angle valves are similar to globe valves; however, the inlet and outlet ports are at 90° angles to one another, rather than at 180° angles. because of this difference, the angle valves have slightly less resistance to flow than globe valves. However, both valve types operate similarly in principle and, for the purposes of this document, discussion of globe valves will also pertain to angle valves.

The seating of the plug in a globe valve is parallel to the line of liquid flow. Because of this seating arrangement, globe valves are very suitable for

throttling flow with a minimal seat erosion or threat of wire drawing.

A globe valve opens in direct proportion to the number of turns of its actuator. This features allows globe valves to closely regulate flow, even with manual operators. For example, if it takes four turns to open a globe valve fully, then approximately one turn of a hand wheel will release about 25% of the flow, two turns will release 50% , and three turns will release 75%. In addition, the shorter travel saves time and work, as well as wear on valve parts.

Maintenance is relatively easy with globe valves. The seats discs are plugs, and most globe valves can be repaired without actually removing the valve from the pipe.



CAST STEEL GLOBE VALVES BS-1873 / ASME B16.34

Bolted Bonnet Os & Yoke Type, Rising Stem, Flanged/butt Weld Ends

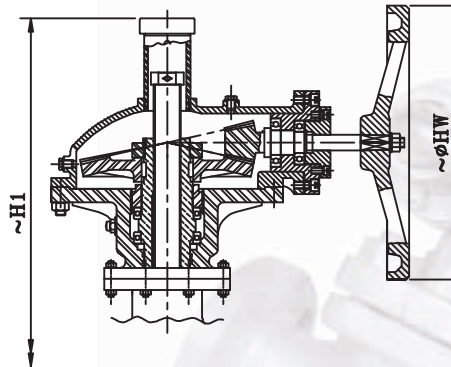
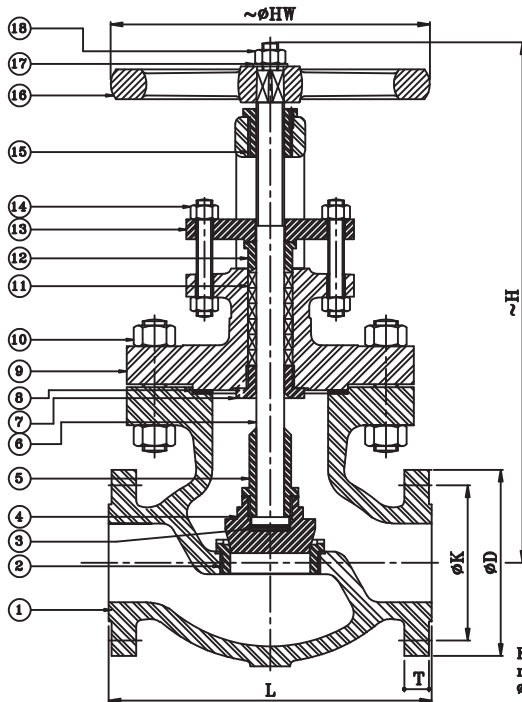

NOTE:

- (1) CLASS 150 & 300 FLANGES ARE FURNISHED WITH 2mm RAISED FACE (f)
- (2) CLASS 600 & ABOVE FLANGES ARE FURNISHED WITH 7mm RAISED FACE (f) WHICH IS ADDITIONAL TO THE FLANGE THICKNESS (T)
- (3) BUTT WELD ENDS AS PER ANSI B: 16.25.

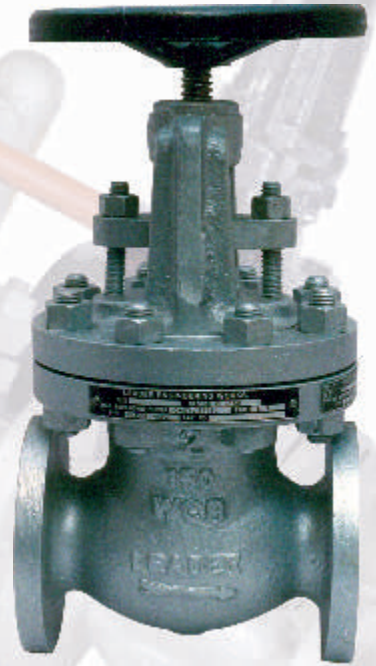

STANDARD MATERIAL COMBINATION

P. No	PART NAME	Carbon steel to ASTM		Alloy steel to ASTM					Stainless steel to ASTM			
		Type WCB	Type LCB	Type WC1	Type WC6	Type WC9	Type C5	Type C12	Type CF8	Type CF8M	Type CF3	Type CF3M
1	BODY	A216 WCB	A352 LCB	A217 WC1	A217 WC6	A217 WC9	A217 C5	A217 C12	A351 CF8	A351 CF8M	A351 CF3	A351 CF3M
2	BODY SEAT RING	As per Trim Material Combination										
3	THRUST PLATE	HARDENED STEEL										
4	DISC	As per Trim Material Combination										
5	DISC NUT	A182 F6a	F304	A182 F6a	A182 F6a	A182 F6a	A182 F6a	A182 F6a	A276 F304	A182 F316	A182 304L	A182 316L
6	STEM	As per Trim Material Combination										
7	BACK SEAT BUSH	As per Trim Material Combination										
8	GASKET	Spiral wound Stainless steel Graphoil filled										
9	BONNET	A216 WCB	A352 LCB	A217 Wc1	A217 WC6	A217 WC9	A217 C5	A217 C12	A315 CF8	A351 CF8M	A351 CF3	A351 CF3M
10	BODY BONNET STUDS & NUTS	A193 B7 A194 2H	A320 L7 A194 4	A193 B7 A194 2H	A193 B16 A194 4	A193 B16 A194 4	A193 B16 A194 4	A193 B16 A194 4	A193 B8 A194 8	A193 B8 A194 8M	A193 B8 A194 8	A193 B8 A194 8M
11	PACKING	To Suit service conditions										
12	GLAND	A182 F6a	A182 F6a	A182 F6a	A182 F6a	A182 F6a	A182 F6a	A182 F6a	A276 F304	A182 F316	A182 304L	A182 316L
13	GLAND FLANGE	A105	A350 LF2	A105	A105	A105	A105	A105	A351 CF8	A351 CF8M	A351 CF3	A351 CF3M
14	STUDS & NUTS	A193 B7 A194 2H	A320 L7 A194 Gr.4	A193 B7 A194 2H	A193 B16 A194 Gr.4	A193 B16 A194 Gr.4	A193 B16 A194 Gr.4	A193 B16 A194 Gr.4	A193 B8 A194Gr.8	A193 B8 A194 Gr.8	A193 B8 A194 Gr.8	A193 B8 A194 Gr.8
15	YOKE BUSH	Al. Bronze BS 1982 CC331G or Ni-resist to A4390D2										
16	HANDWHEEL	DI A536 80-55-06 OR MI 1S2108 BM290/ASTMA338										
17	WASHER	STEEL										
18	HANDWHEEL RETAINING NUT	STEEL										

NOTE: The above data is subject to change without notice due to our continuing product improvement program.



CAST STEEL GLOBE VALVES BS-1873 / ASME B16.34

TRIM MATERIAL COMBINATION (ON REQUEST)

Trim No.	Seat Ring Face	Wedge Seat Face	Stem	Backseat Bush	Lantern Ring
1	F6a/13%Cr.	F6a/13%Cr.	F6a/AISI410	F6a/AISI410	F6a/AISI410
2	F304	F304	F304/AISI304	F304/AISI304	F304/AISI304
5	STELLITE	STELLITE	F6a/AISI410	F6a/AISI410	F6a/AISI410
8	STELLITE	F6a/13%Cr.	F6a/AISI410	F6a/AISI410	F6a/AISI410
9	MONEL	MONEL	MONEL	MONEL	MONEL
10	F316	F316	F316/AISI316	F316/AISI316	F316/AISI316
12	316+STELLITE	316	F316/AISI316	F316/AISI316	F316/AISI316
13	ALLOY 20	ALLOY 20	ALLOY 20	ALLOY 20	ALLOY 20

NOTE: Other Trim Combination can be given.

DIMENSIONAL DATA CLASS-150

•All dimensions in mm

DN	40	50	65	80	100	125	150	200	250	300*	350*	400*	500*
NPS	1 ½	2	2 ½	3	4	5	6	8	10	12	14	16	20
L	165	203	216	241	292	356	406	495	622	698	787	914	978
L1	165	203	216	241	292	356	406	495	622	698	787	914	978
L2	178	216	229	254	305	369	419	508	635	711	800	927	991
φD	125	150	180	190	230	255	280	345	405	485	535	595	700
T	12.7	14.3	15.9	17.5	22.3	22.3	23.9	27	28.6	30.2	33.4	35	41.3
K(PCD)	98.5	120.7	139.7	152.4	190.5	215.9	241.3	298.5	361.9	431.8	476.3	539.8	635
n	04	04	04	04	08	08	08	08	12	12	12	16	20
φd	15.7	19.1	19.1	19.1	19.1	22.3	22.3	22.3	25.4	25.4	28.6	28.6	32
~H(Close)	295	330	422	445	490	570	600	642	770	825	1180	1220	2085
~H(Open)	305	343	438	465	515	601	638	692	833	900	1268	1320	2210
~H1	-	-	-	-	-	-	-	-	-	1112	-	1220	1941
φHW	203	203	229	229	254	254	304	457	559	635	450	450	700
Aprox.wt. ^	16.5	25.5	35	44	77	102	126	220	337	564	803	851	---

DIMENSIONAL DATA CLASS-300

DN	40	50	65	80	100	125	150	200	250	300*	400*	500*	600*
NPS	1 ½	2	2 ½	3	4	5	6	8	10	12	16	20	24
L	229	267	292	318	356	401	444	559	622	711	864	1016	1346
L1	229	267	292	318	356	401	444	559	622	711	----	----	----
L2	242	283	308	334	372	417	460	575	638	727	880	1035	1368
φD	155	165	190	210	255	280	320	380	445	520	650	775	915
T	19.1	20.7	23.9	27	30.2	33.4	35	39.7	46.1	49.3	55.6	62	68.3
K(PCD)	114.3	127	149.3	168.1	200.1	234.9	269.7	330.2	387.3	450.8	511.5	685.8	812.8
n	04	08	08	08	08	08	12	12	16	16	20	24	24
φd	22.3	19.1	22.3	22.3	22.3	22.3	22.3	25.4	28.6	31.8	34.9	35	41.3
~H(Close)	360	400	420	515	590	680	680	820	835	1000	----	----	----
~H(Open)	370	413	436	535	615	711	718	870	898	1075	----	----	----
~H1	-	-	-	-	-	-	-	-	-	1460	1639	2084	-
φHW	216	216	254	254	356	406	457	508	559	864	----	----	----
Aprox.wt. ^	26	37.5	60	68.5	103	164	221	318	572	679	----	----	----

NOTE: The above data is subject to change without notice due to our continuing product improvement program. (^WEIGHT GIVEN IN KGS)

RTJ Face to Face as per ASME B16.10 Standard. Flanges upto 24" as per ASME B16.5. Butt Weld Ends as per ANSI B 16.25.

*For Gear Operated Valve



•All dimensions in mm

DIMENSIONAL DATA CLASS-600

DN	50	65	80	100	125	150*	200*	250*	300*	400*
NPS	2	2 ½	3	4	5	6	8	10	12	16
L	292	330	356	432	508	559	660	787	838.2	1194
L1	292	330	356	432	508	559	660	787	838.2	1194
L2	295	330	259	435	511	562	663	790	842	1197
φD	165	190	210	275	330	355	420	510	560	685
T	25.4	28.6	31.8	38.1	44.4	47.7	55.6	63.5	66.7	76.2
K(PCD)	127	149.2	168.3	215.9	266.7	292.1	349.2	431.8	489	603.2
n	08	08	08	08	08	12	12	16	20	20
φd	19	22.2	22.2	25.4	28.6	28.6	31.8	34.9	35	41.2
~H(Close)(H1)	400	515	530	645	750	800	830	860	884	-
~H(Open)	410	528	550	670	781	-	-	-	-	-
φHW	254	305	305	457	508	599	610	650	650	-
Aprox.wt. ^	42.5	66	88	164.5	-	340	495	834	996.	750 -

DIMENSIONAL DATA CLASS-900

DN	50	80	100	150*	200*	250*	300*
NPS	2	3	4	6	8	10	12
L	368	381	457.5	610	736.6	838	965
L1	368	281	457.5	610	736.6	838	965
L2	371	384	461	613	740	841	968
φD	215	240	290	380	470	545	610
T	38.1	38.1	44.5	55.6	63.5	69.9	79.4
K(PCD)	165.1	190.5	234.5	317.5	393.7	469.9	533.4
n	08	08	08	12	12	16	20
φd	25.4	25.4	31.8	31.8	38.1	38.1	38.1
~H(Close) (H1)	620	690	840	1145	1145	1300	1400
~H(Open)	633	810	865	-	-	-	-
φHW	300	300	400	450	450	450	450
Aprox.wt. ^	105.2	162	218	603	930	1360	1960

DIMENSIONAL DATA CLASS-1500

DN	50	65	80*	100*	150*	200*	250*	300*
NPS	2	2 ½	3	4	6	8	10	12
L	368	419	470	546	705	832	991	1130
L1	368	419	470	546	705	832	991	1130
L2	371	422	473	549	711	342	1001	1146
φD	215	145	265	310	345	485	585	670
T	38.1	41.3	47.7	54	82.6	92.1	108	123.9
K(PCD)	165.1	203.2	203.2	241.3	317.5	393.7	482.6	571.5
n	08	08	08	08	12	12	12	16
φd	25.4	31.8	31.8	35	38.1	44.5	50.8	53.8
~H(Close)(H1)	610	660	970	1140	1700	1690	1800	2200
~H(Open)	624	678	-	-	-	-	-	-
φHW	300	350	450	450	450	450	700	700
Aprox.wt. ^	42	98	148.2	174.5	517	1245	3068.3	1701.4

NOTE: The above data is subject to change without notice due to our continuing product improvement program. (^WEIGHT GIVEN IN KGS)

*For Gear Operated Valve - Flanges upto 24" as per ASME B16.5. Butt Weld Ends as per ANSI B 16.25. H1 for gear operated valves.

TEST PRESSURES

CLASS	SHELL TEST (HYDROSTATIC)		SEAT TEST			
			HYDROSTATIC		PNEUMATIC	
150	30 Bar	435 Psi g	22 Bar	319 Psi g	6.9 bar	100 Psi g
300	77 Bar	1102 Psi g	57 Bar	780 Psi g	6.9 bar	100 Psi g
600	154 Bar	2175 Psi g	113 Bar	1595 Psi g	6.9 bar	100 Psi g
900	230 Bar	3350 Psi g	169 Bar	2451 Psi g	6.9 bar	100 Psi g
1500	384 Bar	5568 Psi g	282 Bar	4075 Psi g	6.9 bar	100 Psi g



CAST STEEL GLOBE VALVES PRESSURE SEAL BONNET OS & YOKE TYPE RISING STEM BUTT WELD/FLANGED ENDS ASME B16.34

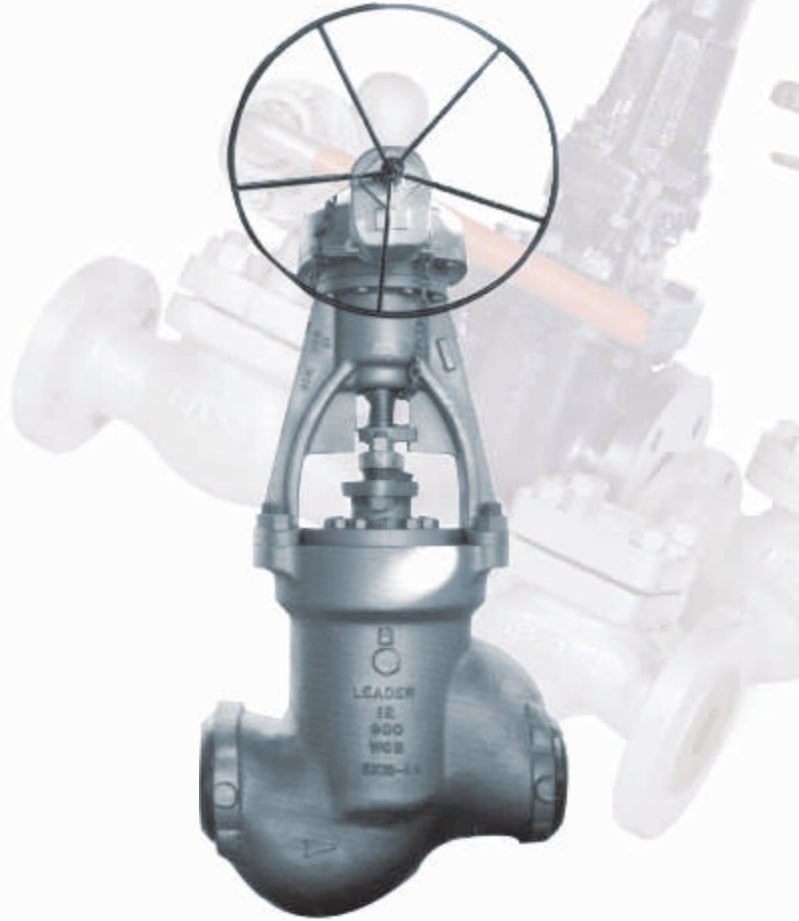
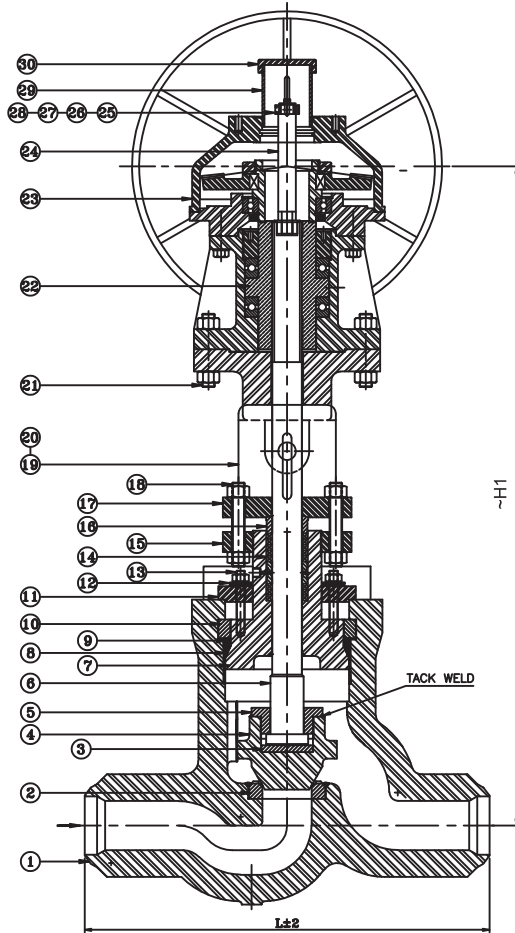

STANDARD MATERIAL COMBINATION

P. No	PART NAME	Carbon steel to ASTM		Alloy steel to ASTM					Stainless steel to ASTM			
		Type WCB	Type LCB	Type WC1	Type WC6	Type WC9	Type C5	Type C12	Type CF8	Type CF8M	Type CF3	Type CF3M
1	BODY	A216 WCB	A352 LCB	A217 WC1	A217 WC6	A217 WC9	A217 C5	A217 C12	A351 CF8	A351 CF8M	A351 CF3	A351 CF3M
2	BODY SEAT RING	As per Trim Material Combination										
3	THRUST PLATE	HARDENED STEEL										
4	DISC	As per Trim Material Combination										
5	DISC NUT	A182 F6a	F304	A182 F6a	A182 F6a	A182 F6a	A182 F6a	A182 F6a	A276 F304	A182 F316	A182 304L	A182 316L
6	STEM	As per Trim Material Combination										
7	BONNET	A216 WCB	A352 LCB	A217 WC1	A217 WC6	A217 WC9	A217 C5	A217 C12	A351 CF8	A351 CF8M	A351 CF3	A351 CF3M
8	PRESSURE SEAL GASKET	GRAPHITE										
9	PRESSURE RING	A216 WCB	A352 LCB	A217WC1	A217WC6	A217 WC9	A217 C5	A217 C12	A351 CF8	A351 CF8M	A351 CF3	A351 CF3M
10	SEGMENTED RING	A216 WCB	A352 LCB	A217WC1	A217WC6	A217 WC9	A217 C5	A217 C12	A351 CF8	A351 CF8M	A351 CF3	A351 CF3M
11	BONNET RETAINING PLATE	A216 WCB	A352 LCB	A217WC1	A217WC6	A217 WC9	A217 C5	A217 C12	A315 CF8	A351 CF8M	A351 CF3	A351 CF3M
12	BELLEVEILLE WASHER	Blackened Steel										
13	BODY BONNET STUDS & NUTS	A193 B7 A194 2H	A320 L7 A194 4	A193 B7 A194 2H	A193 B16 A194 4	A193 B16 A194 4	A193 B16 A194 4	A193 B16 A194 4	A193 B8 A194 8	A193 B8 A194 8M	A193 B8 A194 8	A193 B8 A194 8M



Cast Steel Globe Valves Pressure Seal Bonnet OS & Yoke Type Rising Stem Butt Weld/Flanged Ends ASME B16.34

14	GLAND PACKING	FLEXIBLE GRAPHITE										
15	CLAMP	A216 WCB	A352 LCB	A217 WC1	A217WC6	A217WC9	A217 C5	A217 C12	A351 CF8	CF8M	CF3	CF3M
16	GLAND FOLLOWER	A182 F6a	A182 F6a	A182 F6a	A182 F6a	A182 F6a	A182 F6a	A182 F6a	A276 F304	A182 F316	A182 304L	A182 316L
17	GLAND FLANGE	A216 WCB	A352 LCB	A217 WC1	A217WC6	A217WC9	A217 C5	A217 C12	A351 CF8	CF8M	CF3	CF3M
18	GLAND STUDS & NUTS	A193 B7 A194 2H	A320 L7 A194 Gr.4	A193 B7 A194 2H	A193 B16 A194 Gr.4	A193 B16 A194 Gr.4	A193 B16 A194 Gr.4	A193 B16 A194 Gr.4	A193 B8 A194Gr.8	A193 B8 A194 Gr.8	A193 B8 A194 Gr.8	A193 B8 A194 Gr.8
19	YOKE	A216 WCB	A352 LCB	A217 WC1	A217WC6	A217WC9	A217 C5	A217 C12	A351 CF8	CF8M	CF3	CF3M
20	YOKE STUD & NUT	A193 B7 A194 2H	A320 L7 A194 Gr.4	A193 B7 A194 2H	A193 B16 A194 Gr.4	A193 B16 A194 Gr.4	A193 B16 A194 Gr.4	A193 B16 A194 Gr.4	A193 B8 A194Gr.8	A193 B8 A194 Gr.8	A193 B8 A194 Gr.8	A193 B8 A194 Gr.8
22	YOKE SLEEVE	Al. Bronze BS 1982 CC331G or Ni-resist to A4390D2										
23	YOKE	A216 WCB	A352 LCB	A217 WC1	A217WC6	A217WC9	A217 C5	A217 C12	A351 CF8	CF8M	CF3	CF3M
27	WASHER	STEEL										
29	PIPE	CARBON STEEL										
30	CAP	CARBON STEEL										

NOTE: The above data is subject to change without notice due to our continuing product improvement program.

TRIM MATERIAL COMBINATION (ON REQUEST)

Trim No.	Seat Ring Face	Wedge Seat Face	Stem	Backseat Bush	Lantern Ring
1	F6a/13%Cr.	F6a/13%Cr.	F6a/AISI410	F6a/AISI410	F6a/AISI410
2	F304	F304	F304/AISI304	F304/AISI304	F304/AISI304
5	STELLITE	STELLITE	F6a/AISI410	F6a/AISI410	F6a/AISI410
8	STELLITE	F6a/13%Cr.	F6a/AISI410	F6a/AISI410	F6a/AISI410
9	MONEL	MONEL	MONEL	MONEL	MONEL
10	F316	F316	F316/AISI316	F316/AISI316	F316/AISI316
12	316+STELLITE	316	F316/AISI316	F316/AISI316	F316/AISI316
13	ALLOY 20	ALLOY 20	ALLOY 20	ALLOY 20	ALLOY 20

NOTE: Other Trim Combination of API 600 Can Be Provided on Request. Lantern Ring Can Be Provided If Required Except For CI-150.

•All dimensions in mm

DIMENSIONAL DATA CLASS-900

DN	50	80	100	150*	200*	250*	300*
NPS	2	3	4	6	8	10	12
L	368	381	457.5	610	736.6	838	965
L1	368	281	457.5	610	736.6	838	965
L2	371	384	461	613	740	841	968
φD	215	240	290	380	470	545	610
T	38.1	38.1	44.5	55.6	63.5	69.9	79.4
K(PCD)	165.1	190.5	234.5	317.5	393.7	469.9	533.4
n	08	08	08	12	12	16	20
φd	25.4	25.4	31.8	31.8	38.1	38.1	38.1
~H(Close)(H1)	620	690	840	1145	1145	1300	1400
~H(Open)	633	810	865	-	-	-	-
φHW	300	300	400	450	450	450	450
Aprox.wt. ▲	105.2	162	218	603	930	1360	1960



Cast Steel Globe Valves Pressure Seal Bonnet OS & Yoke Type Rising Stem Butt Weld/Flanged Ends ASME B16.34

•All dimensions in mm

DIMENSIONAL DATA CLASS-1500

	50	65	80*	100*	150*	200*	250*	300*
DN	50	65	80*	100*	150*	200*	250*	300*
NPS	2	2 ½	3	4	6	8	10	12
L	368	419	470	546	705	832	991	1130
L1	368	419	470	546	705	832	991	1130
L2	371	422	473	549	711	842	1001	1146
φD	215	145	265	310	345	485	585	670
T	38.1	41.3	47.7	54	82.6	92.1	108	123.9
K(PCD)	165.1	203.2	203.2	241.3	317.5	393.7	482.6	571.5
n	08	08	08	08	12	12	12	16
φd	25.4	31.8	31.8	35	38.1	44.5	50.8	53.8
~H(Open)(H1)	610	660	970	1140	1700	1690	1800	2200
~H(Close)	624	678	-	-	-	-	-	-
φHW	300	350	450	450	450	450	700	700
Aprox.wt. ▲	42	98	148.2	174.5	517	1245	3068.3	1701.4

DIMENSIONAL DATA CLASS-2500

	50	65	80*	100*	150*	200*
DN	50	65	80*	100*	150*	200*
NPS	2	2 ½	3	4	6	8
L	451	508	578	673	914	1022
L1	451	508	578	673	914	1022
L2	454	511	581	677	918	1027
φD	235	265	305	355	485	550
T	50.9	57.2	66.7	76.2	108	165.1
K(PCD)	171.5	196.6	228.6	273	368.3	438.2
n	08	08	08	08	08	12
φd	28.5	31.8	35.1	41.2	53.9	53.9
~H(Close)(H1)	610	650	750	850	1100	1300
~H(Open)	625	666	-	-	-	-
φHW	350	350	450	450	700	700
Aprox.wt. ▲	116	178.5	241	665	1025	1499.5

NOTE: The above data is subject to change without notice due to our continuing product improvement program. (▲WEIGHT GIVEN IN KGS)

*For Gear Operated Valves. - Flanges as per ASME B16.5. Butt Weld Ends as per ANSI B 16.25. H1 for gear operated valves.

TEST PRESSURES

CLASS	SHELL TEST (HYDROSTATIC)		SEAT TEST			
			HYDROSTATIC		PNEUMATIC	
900	230 Bar	3350 Psi g	169 Bar	2451 Psi g	6.9 bar	100 Psi g
1500	384 Bar	5568 Psi g	282 Bar	4075 Psi g	6.9 bar	100 Psi g
2500	639 Bar	9372 Psi g	469 Bar	6785 Psi g	6.9 bar	100 Psi g



CAST STEEL LOW TEMPERATURE CRYOGENIC GLOBE VALVES BS:1873, BS:6364, EXTENDED BONNET

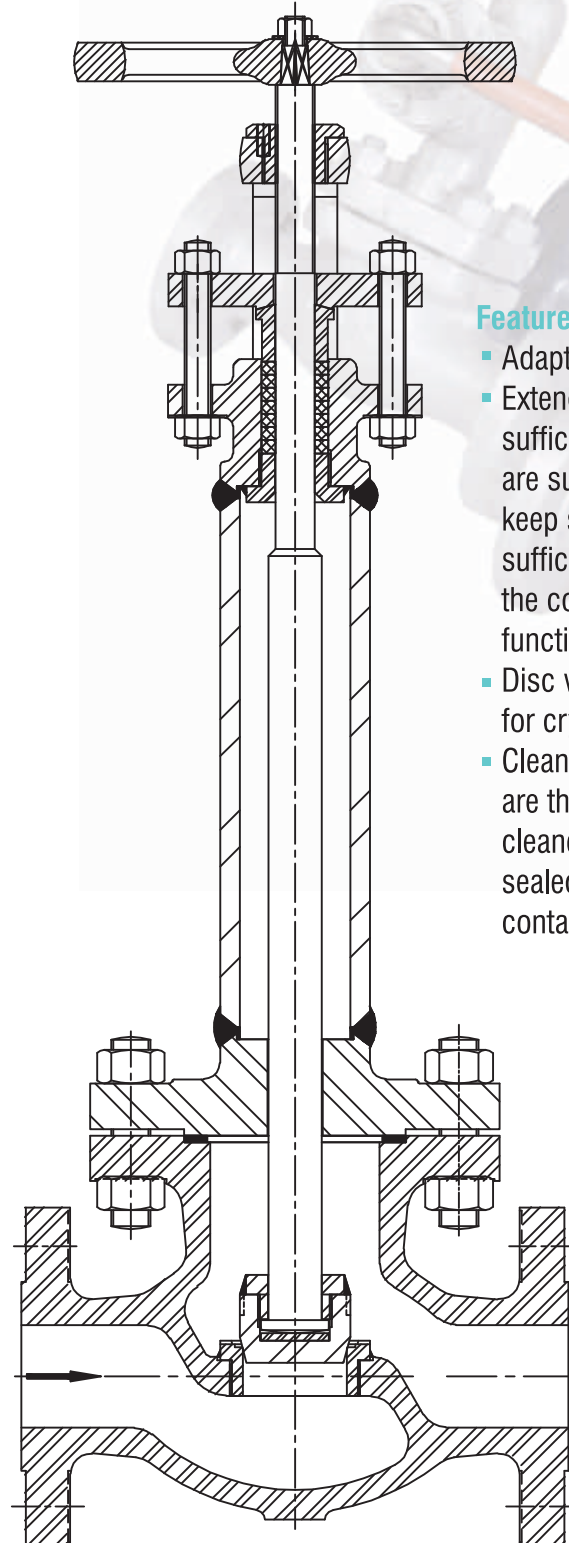

Features and benefits

- Adapted to Special Service
- Extended bonnets with sufficient gas column length, are supplied for all valves to keep stem packing at sufficient distance away from the cold fluid to remain functional.
- Disc with Stellite seating faces for cryogenic service.
- Cleaning: All cryogenic valves are thoroughly degreased and cleaned and pipe ends are sealed to prevent contamination.



CAST STEEL GLOBE VALVES BS: 5160/DIN: 2401

SPECIFICATIONS

BOLTED BONNET, RISING STEM, S.S. TRIM, FLANGES AS PER DIN STD 2545 : PN 40 (R.F.)

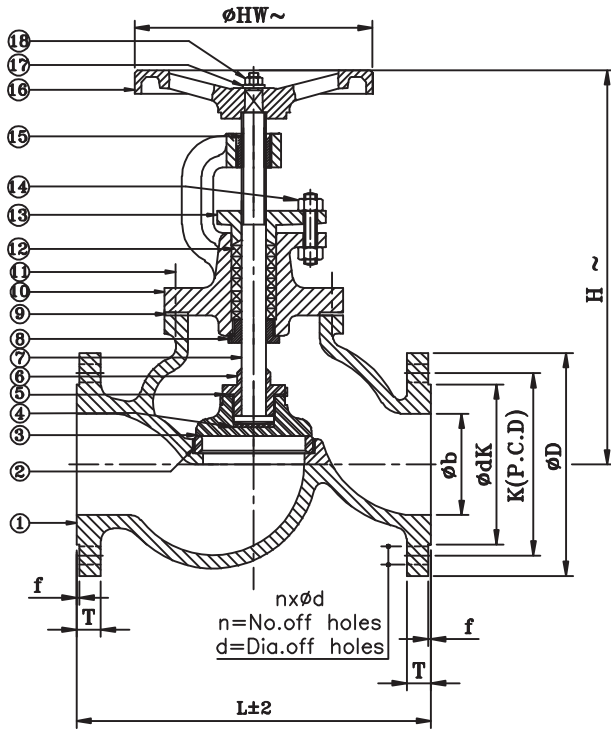

STANDARD MATERIAL COMBINATION

P.NO.	DESCRIPTION	MATERIALS	SPECIFICATIONS
1.	BODY	C.C.S.	ASTM A216 Gr.WCB
2.	BODY SEAT RING (HB-250 Min)	13% Cr. STEEL	ASTM 1 182:01 Gr. F6a
3.	DISC (HB-300 Min)	C.C.S.	ASTM A216 Gr.WCB 13% Cr. WELD DEPOSIT
4.	THRUST PLATE	HARDENED STEEL	-----
5.	LOCKING WASHER	S.S.	ANY GRADE
6.	DISC NUT (HB-250 Min)	13% Cr. STEEL	ASTM A276 TYPE410/ASTM A 182 Gr. F6a
7.	STEM (HB-200 Min)	13% Cr. STEEL	ASTM A276 TYPE410/ASTM A 182 Gr. F6a
8.	BACK SEAT BUSH (HB-250 Min)	13% Cr. STEEL	ASTM A276 TYPE410/ASTM A 182 Gr. F6a
9.	GASKET	SPRIAL WOUND S.S.304 WITH GRAPHITE FILLER	
10.	BONNET	C.C.S.	ASTM A216 Gr.WCB
11.	STUDS & NUTS	ALLOY STEEL/H.T.STEEL	ASTM A 193 GR. B7/ ASTM A 194 Gr.2H
12.	PACKING		FLEXIBLE GRAPHITE
13.	GLAND	C.C.S.	ASTM A216 Gr.WCB
14.	STUDS & NUTS	ALLOY STEEL/H.T.STEEL	ASTM A 193 Gr.B7/ ASTM A 194 Gr.2H
15.	YOKE BUSH	AL. BRONZE	BSEN 1982 Gr. CC333G
16.	HAND WHEEL	D.I.	ASTM A536 Gr. 80-55-06
17.	WASHER	CARBON STEEL	IS 2062 Gr.A
18.	NUT FOR HANDWHEEL	CARBON STEEL	BS 916-53

NOTE: The above data is subject to change without notice due to our continuing product improvement program.



CAST STEEL GLOBE VALVES BS: 5160/DIN: 2401

SPECIFICATIONS

BOLTED BONNET, RISING STEM, S.S. TRIM, FLANGES AS PER DIN STD 2545 : PN 40 (R.F.)

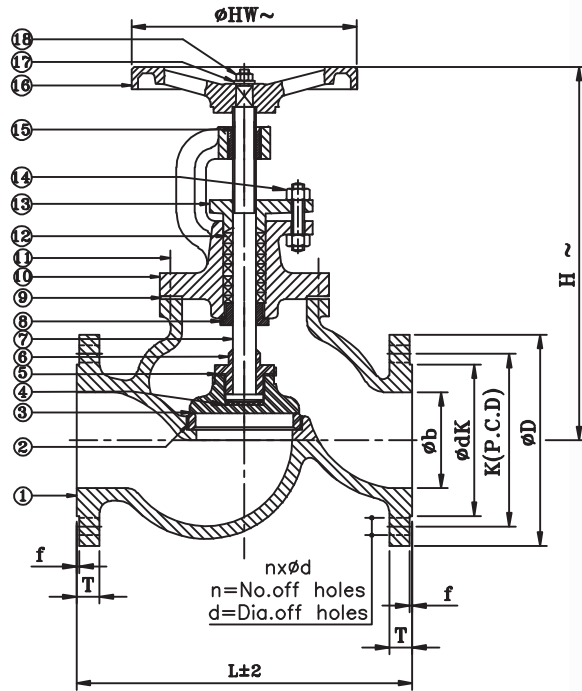

• All dimensions in mm

PRESSURE / TEMPERATURE RATINGS TO BS 5160/DIN 2401

NOMINAL PRESSURE	MAX. PERMISSIBLE GAUGE WORKING PRESSURE °C						
	10 TO 120°C	200°C	250°C	300 °C	350 °C	400 °C	425 °C
PN 40	40 bar	40bar	38bar	33bar	28bar	23bar	20bar

DIMENSIONAL DATA

DN NPS	15 1/2"	20 3/4"	25 1"	32 1-1/4"	40 1-1/2"	50 2"	65 2-1/2"	80 3"	100 4"	125 5"	150 6"	200 8"	250 10"	300 12"
$\phi HW \sim$	125	125	160	160	200	200	250	250	300	300	300	350	400	400
L	130	150	160	180	200	230	290	310	350	400	480	600	730	850
ϕb	15	20	25	32	40	50	65	80	100	125	150	200	250	300
ϕD	95	105	115	140	150	165	185	200	235	270	300	375	450	515
$\sim H$ (Close)	190	196	225	236	291	314	325	380	435	468	555	645	-	-
$\sim H$ (Open)	194	201	231	244	301	327	341	400	460	499	593	695	-	-
dk	45	58	68	78	88	102	122	138	162	188	218	285	345	410
K	65	75	85	100	110	125	145	160	190	220	250	320	385	450
n	4	4	4	4	4	4	8	8	8	8	8	12	12	16
ϕd	14	14	14	18	18	18	18	18	22	26	26	30	33	33
Aprox. Wt. Δ	3.23	4.85	6.35	11.7	14	20.3	32.8	42.5	66.5	105.7	169.3	268	419	660

TEST PRESSURES

NOMINAL PRESSURE RATING	SHELL TEST (HYDROSTATIC)	SEAT TEST (HYDROSTATIC & 6:9 BAR (AIR))
PN 40	60 bar	40 bar

NOTE: The above data is subject to change without notice due to our continuing product improvement program.



CAST STEEL GLOBE VALVES BS: 5160/DIN: 2401

SPECIFICATIONS

BOLTED BONNET, O/S & YOKE TYPE, RISING STEM, S.S. TRIM, FLANGES AS PER DIN STD 2545 PN 40 (R.F.)

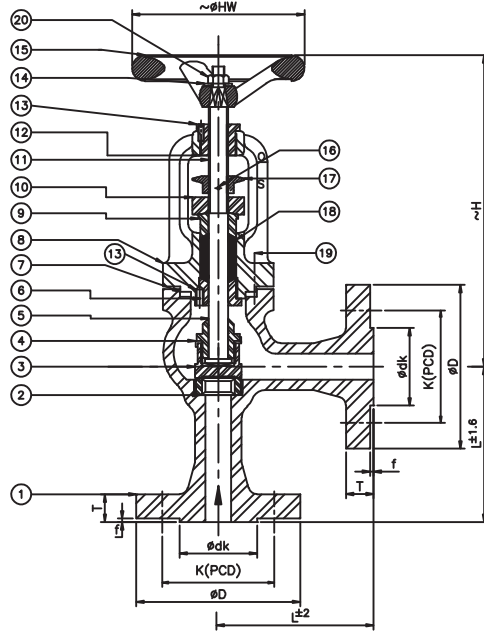

STANDARD MATERIAL COMBINATION

P.NO.	DESCRIPTION	MATERIALS	SPECIFICATIONS
1.	BODY	C.S.	ASTM A216 Gr. WCB
2.	BODY SEAT RING (HB 250 MIN)	13% Cr. STEEL	ASTM A182 Gr. F6a OR its Eq.
3.	DISC (HB 300MIN.)	S.S.(UP TO SIZE 50mm) C.S. (For Size 65mm & ABOVE)	ASTMA 182 Gr.F6a ASTMA 216 Gr.WCB 13% Cr. Weld deposit
4.	LOCKING WASHER	S.S.	-----
5.	STEM NUT (HB 250mm)	13% Cr. STEEL	ASTMA 182 Gr.F6a or its Eq.
6.	BACK SEAT BUSH	13% Cr. STEEL	ASTMA 182 Gr.F6a or its Eq.
7.	GASKET	SPIRAL WOUND STAINLESS STEEL (TYPE 304) GRAPHITE FILLER	
8.	BONNET	C.S.	ASTMA 216 Gr.WCB
9.	GLAND	13% Cr. STEEL	ASTMA 182 Gr. F6a or its Eq.
10.	GLAND FLANGE	C.S.	ASTM A216 Gr. WCB
11.	STEM (HB 200mm)	13% Cr. STEEL	ASTMA 182 Gr.F6a / ASTMA 276 TYPE410 or its Eq.
12.	YOKE BUSH	AL. BRONZE/NODULAR IRON	BS 1400-85 AB 2 C/BS 2874-84 CA 104/ ASTMA 439-83 Gr.D2
13.	GRUB SCREW	STEEL	-----
14.	WASHER	STEEL	-----
15.	HANDWHEEL	C.S./SG IRON M.I.	ASTMA 216 Gr. WCB/BS 2789 Gr.32/7/IS 2108-77 Gr. BM 290
16.	WASHER	13% Cr. STEEL	ASTMA 182 Gr.F6a or its Eq.
17.	INDICATOR	GUN METAL	BS 1400 Gr.LG2C
18.	GLAND PACKING	BRAIDED GRAPHOIL CONTAINING CORROSION INHABITOR SUITABLE FOR MAX. DESIGN TEMP. 53 8°C	
19.	STUDS & NUTS	ALLOY STEEL & H.T.STEEL	ASTM A193 Gr.B7 & ASTM 194 Gr. 2H
20.	NUT FOR HANDWHEEL	STEEL	-----

NOTE: The above data is subject to change without notice due to our continuing product improvement program.



CAST STEEL GLOBE VALVES BS: 5160/DIN: 2401

SPECIFICATIONS

BOLTED BONNET, O/S & YOKE TYPE, RISING STEM, S.S. TRIM, FLANGES as per DIN STD 2545 PN 40 (R.F.)

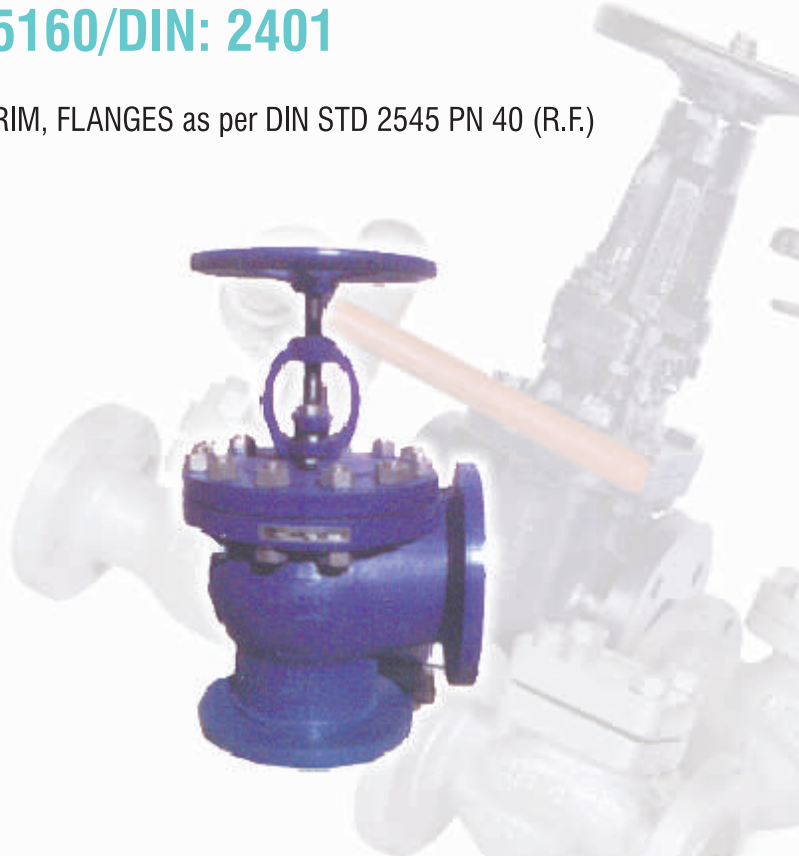
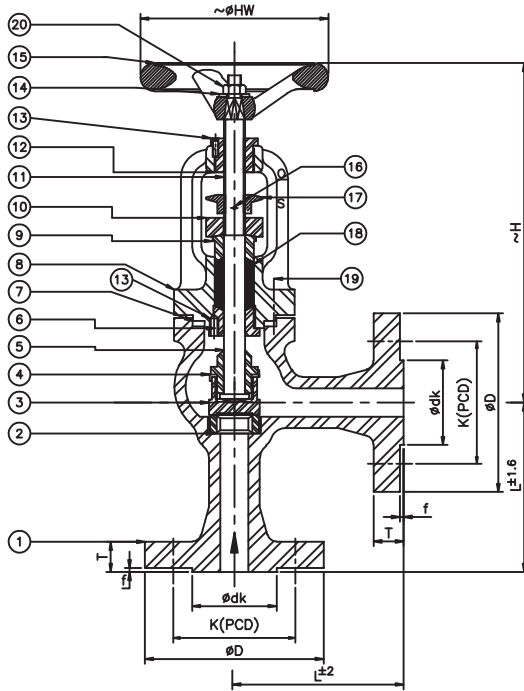

• All dimensions in mm

PRESSURE / TEMPERATURE RATINGS TO BS 5160/DIN 2401

NOMINAL PRESSURE	MAX. PERMISSIBLE GAUGE WORKING PRESSURE °C						
	10 TO 120°C	200°C	250°C	300 °C	350 °C	400 °C	425 °C
PN 40	40 bar	40bar	38bar	33bar	28bar	23bar	20bar

DIMENSIONAL DATA

DN NPS	15 1/2'	20 3/4"	25 1"	32 1-1/4"	40 1-1/2"	50 2"	65 2-1/2"	80 3"	100 4"	125 5"	150 6"	200 8"	250 10"	300 12"
L	90	95	100	105	115	125	145	155	175	200	225	275	325	375
~H(Close)	145	145	145	175	190	225	250	280	330	365	412	418	575	590
~H(Open)	149	150	151	183	200	238	266	300	355	396	450	468	638	665
HWø	120	120	120	120	140	140	180	180	235	260	320	400	400	400
Dø	95	105	115	140	150	165	185	200	235	270	300	375	450	815
T	16	18	18	18	18	20	22	24	24	26	28	34	38	42
dkø	45	58	68	78	88	102	122	138	162	188	218	285	345	410
f	2	2	2	2	3	3	3	3	3	3	3	3	3	4
k	65	75	85	100	110	125	145	160	190	220	250	320	385	450
n	4	4	4	4	4	4	8	8	8	8	8	12	12	16
dø	14	14	14	18	18	18	18	18	22	26	26	30	33	33
Aprox. Wt. ^	5.6	7.2	8.75	12	15.2	17.9	29.35	40.9	59.35	92.7	139.5	225	321	403

TEST PRESSURES

NOMINAL PRESSURE RATING	SHELL TEST (HYDROSTATIC)	SEAT TEST (HYDROSTATIC & 6:9 BAR (AIR))
PN 40	60 bar	40 bar

NOTE: The above data is subject to change without notice due to our continuing product improvement program.



General Description



CAST STEEL CHECK VALVE

Check valves are self-actuated. These valves are opened, and sustained in the open position, by the force of the liquid velocity pressure. They are closed by the force of gravity or backflow. The seating load and tightness is dependent upon the amount of back pressure. Typical check valves include swing check, tilting disc check, lift check, and stop check. Other check valve types are available, however.

Swing check valves are used to prevent flow reversal in horizontal or vertical upward pipelines

(vertical pipes or pipes in any angle from horizontal to vertical with upward flow only). Swing check valves have discs that swing open and closed. The discs are typically designed to close on their own weight, and may be in a state of constant movement if velocity pressure is not sufficient to hold the valve in a wide open position. Premature wear or noisy operation of the swing check valves can be avoided by selecting the correct size on the basis of flow conditions.



CAST STEEL SWING CHECK VALVES- BS 1868, API-6D, ASME B16.34

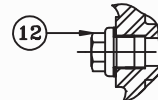
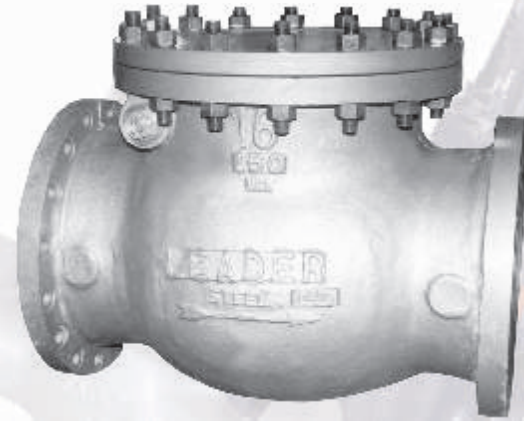
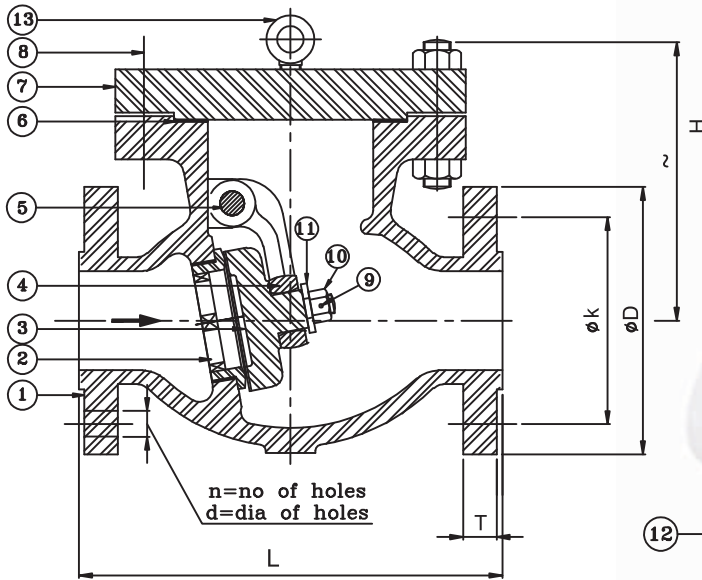

n=No. of holes
Ød=Dia. of holes

STANDARD MATERIAL COMBINATION

P. NO.	PART DESCRIPTION	Carbon steel to ASTM		Alloy steel to ASTM					Stainless steel to ASTM			
		Type WCB	Type LCB	Type WC1	Type WC6	Type WC9	Type C5	Type C12	Type CF8	Type CF8M	Type CF3	Type CF3M
1	BODY	A216 WCB	A352 LCB	A217 WC1	A217 WC6	A217 WC9	A217 C5	A217 C12	A351 CF8	A351 CF8M	A351 CF3	A351 CF3M
2	BODY SEAT RING	A216 WCB	A352 LCB	A217 WC1	A217 WC6	A217 WC9	A217 C5	A217 C12	A351 CF8	A351 CF8M	A351 CF3	A351 CF3M
3	DISC	AS PER TRIM MATERIAL COMBINATION										
4	HING	A216 WCB	A352 LCB	A217 WC1	A217 WC6	A217 WC9	A217 C5	A217 C12	A351 CF8	A351 CF8M	A351 CF3	A351 CF3M
6	GASKET	Stainless Steel + Graphoil										
7	BONNET	A216 WCB	A352 LCB	A217 WC1	A217 WC6	A217 WC9	A217 C5	A217 C12	A351 CF8	A351 CF8M	A351 CF3	A351 CF3M
8	STUD & NUT	A193 B7 A194 2H	A720 L7 A194 Gr4	A193 B16 A194 Gr4	A193 B16 A194 Gr4	A193 B16 A194 Gr4	A193 B16 A194 Gr4	A193 B16 A194 Gr4	A193 B8 A194 Gr8	A193 B8 A194 Gr8	A193 B8 A194 Gr8	A193 B8 A194 Gr8
10	DISC NUT	Stainless Steel										
12	SIDE PLUG	Stainless Steel										
13	LIFTING HOOK	Carbon Steel										

NOTE: The above data is subject to change without notice due to our continuing product improvement program.

TRIM MATERIAL COMBINATION (ON REQUEST)

Trim No.	Seat Ring Face	Wedge Seat Face	Stem	Backseat Bush	Lantern Ring
1	F6a/13%Cr.	F6a/13%Cr.	F6a/AISI410	F6a/AISI410	F6a/AISI410
2	F304	F304	F304/AISI304	F304/AISI304	F304/AISI304
5	STELLITE	STELLITE	F6a/AISI410	F6a/AISI410	F6a/AISI410
8	STELLITE	F6a/13%Cr.	F6a/AISI410	F6a/AISI410	F6a/AISI410
9	MONEL	MONEL	MONEL	MONEL	MONEL
10	F316	F316	F316/AIS1316	F316/AIS1316	F316/AIS1316
12	316+STELLITE	316	F316/AIS1316	F316/AIS1316	F316/AIS1316
13	ALLOY 20	ALLOY 20	ALLOY 20	ALLOY 20	ALLOY 20

NOTE: The above data is subject to change without notice due to our continuing product improvement program.



CAST STEEL SWING CHECK VALVES- BS 1868, API-6D

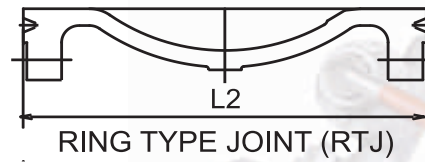
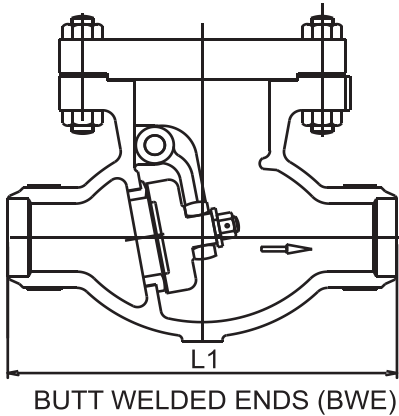

NOTE:

- (1) CLASS 150 & 300 FLANGES ARE FURNISHED WITH 2mm RAISED FACE
- (f) CLASS 600 & ABOVE FLANGES ARE FURNISHED WITH 7mm RAISED FACE (f) WHICH IS ADDITIONAL TO THE FLANGE THICKNESS (T)

• All dimensions in mm

DIMENSIONAL DATA CLASS - 150

DN	40	50	65	80	100	125	150	200	250	300	350	400	450	500	600
NPS	1 ½	2	2 ½	3	4	5	6	8	10	12	14	16	18	20	24
L	165	203	216	241	292	330	356	495	622	698	787	864	978	978	1295
L1	165	203	216	241	292	330	356	495	622	698	787	864	978	978	1295
L2	178	216	229	254	305	343	369	508	635	711	800	877	991	991	1308
D	125	150	180	190	230	255	280	345	405	485	515	595	635	300	815
T	12.7	14.3	15.9	17.5	22.3	22.3	23.9	27	28.6	30.2	33.4	35	38.1	41.3	46.1
K(PCD)	98.4	121.7	139.7	152.4	190.5	215.9	241.3	298.5	362	431.8	476.2	539.8	577.8	635	749.3
n	04	04	04	04	08	08	08	08	12	12	12	16	16	20	20
d	15.9	19	19	19	19	22.2	22.2	22.2	25.4	25.4	28.6	28.6	31.8	31.8	34.9
H	130	140	165	168	190	228	230	261	345	356	425	468	540	600	680
∅b	38	51	64	76	102	127	152	203	254	300	337	387	438	489	591
Aprox.Wt. ^	12	17	27.1	34.5	56	76	93	159	277	580	487	715	905	986	1400

DIMENSIONAL DATA CLASS - 300

DN	40	50	65	80	100	125	150	200	250	300	350	400	450	500	600
NPS	1 ½	2	2 ½	3	4	5	6	8	10	12	14	16	18	20	24
L	241	267	292	318	356	400	444	533	622	711	838	864	978	1016	1346
L1	241	267	292	318	356	400	444	533	622	711	838	864	978	1016	1346
L2	254	283	308	334	372	416	460	549	638	727	854	880	994	1035	1368
D	155	165	190	210	255	280	320	380	445	520	585	650	710	775	915
T	19.1	20.7	23.9	27	30.2	33.4	35	39.7	46.1	49.3	54.4	55.6	58.8	62	68.3
K (PCD)	114.3	127	149.2	168.3	200	235	269.9	330.2	387.3	450.8	514.4	571.5	628.6	685.3	813
n	04	08	08	08	08	08	12	12	16	16	20	20	24	24	24
d	22.2	19	22.2	22.2	22.2	22.2	22.2	25.4	28.6	31.8	31.8	35	35	35	41
H	145	170	182	200	216	320	275	332	385	455	520	785	785	867	1026
∅b	38	51	64	76	102	127	152	203	254	305	337	387	432	483	584
Aprox.Wt. ^	22.3	29	51.1	54.5	75	161.5	161.5	240	380	584	729	865	1158	1580	1975

NOTE: Flanges as per ASME B16.5. Butt Weld Ends as per ANSI B 16.25.

The above data is subject to change without notice due to our continuing product improvement program. (^ WEIGHT GIVEN IN KGS)



CAST STEEL SWING CHECK VALVES- BS 1868, API-6D

•All dimensions in mm

DIMENSIONAL DATA CLASS-600

DN	40	50	65	80	100	125	150	200	250	300	350	400	450	500	600
NPS	1 ½	2	2 ½	3	4	5	6	8	10	12	14	16	18	20	24
L	241	292	330	356	432	508	559	660	787	838	889	991	1092	1194	1397
L1	241	292	330	356	432	508	559	660	787	838	889	991	1092	1194	1397
L2	241	295	333	359	435	511	562	663	790	841	892	994	1095	1200	1419
φD	156	165	190	210	273	330	356	419	508	559	603	685.8	743	812.8	940
T	22.3	25.4	28.6	31.8	38.1	44.4	47.6	55.6	63.5	66.7	69.9	76.2	82.6	88.9	101.6
K(PCD)	114.3	127	149.2	168.3	215.9	266.7	292.1	349.2	431.8	489	527	603.3	654	724	838.2
n	04	08	08	08	08	08	12	12	16	20	20	20	20	24	24
φd	22.2	19	22.2	22.2	25.4	28.6	28.6	31.8	34.9	34.9	38.1	41.2	44.5	44.5	50.8
H	145	170	182	200	216	320	275	332	385	455	580	670	750	820	1109
φb	38	51	64	76	102	127	152	200	248	298	327	375	419	464	591
Aprox.wt. [▲]	33.85	42	62.55	65	157	233.5	274	472	692	875	1270	1346	2080	2746	4275

DIMENSIONAL DATA CLASS-900

DN	40	50	80	100	150	200	250	300	350	400
NPS	1 ½	2	3	4	6	8	10	12	14	16
L	305	368.3	381	457.2	609.6	736.6	838.2	965.2	1029	1130
L1	305	368.3	381	457.2	609.6	736.6	838.2	965.2	1029	1130
L2	305	672	384	460	613	740	841	968	1039	1140
φD	178	216	241.3	292.1	381	470	546.1	609.6	641.4	704.9
T	31.8	38.1	38.1	44.5	55.6	63.5	69.9	79.4	88.9	88.9
K(PCD)	124	165.1	190.5	235	317.5	393.7	469.9	533.4	558.8	616
n	4	08	08	08	12	12	16	20	20	20
φd	28.6	25.4	25.4	31.8	31.8	38.1	38.1	38.1	41.1	44.4
H	188	257	302	340	419	430	550	645	641	780
φb	38	47.5	73	98.3	146	190.5	238	283	311	356
Aprox.wt. [▲]	47.7	94.45	128	214.5	388.5	645	1431	1790	2464	3080

DIMENSIONAL DATA CLASS-1500

DN	50	80	100	150	200	250	300	350
NPS	2	3	4	6	8	10	12	14
L	368.3	470	546	705	832	990.6	1130.3	1257.3
L1	368.3	470	546	705	832	990.6	1130.3	1257.3
L2	371	473	549	711	842	1001	1147	1277
φD	216	266.7	311.1	393.7	482.6	584.2	673.1	749.3
T	38.1	47.7	54	82.6	92.1	108	123.9	133.4
K(PCD)	165.1	203.2	241.3	317.5	393.7	482.6	571.5	635
n	08	08	08	12	12	12	16	16
φd	25.4	31.8	35	38.1	44.5	50.8	53.8	60.4
H	300	450	500	600	700	800	950	1020
φb	48	70	92	137	178	222	264	289
Aprox.wt. [▲]	72	104.8	128.6	330.8	----	----	----	----

NOTE: The above data is subject to change without notice due to our continuing product improvement program. (▲WEIGHT GIVEN IN KGS)
Flanges as per ASME B16.5. Butt Weld Ends as per ANSI B 16.25.

TEST PRESSURES

CLASS	SHELL TEST (HYDROSTATIC)		SEAT TEST HYDROSTATIC	
150	30 Bar	435 Psi g	22 Bar	319 Psi g
300	77 Bar	1102 Psi g	57 Bar	780 Psi g
600	154 Bar	2175 Psi g	113 Bar	1595 Psi g
900	230 Bar	3350 Psi g	169 Bar	2451 Psi g
1500	384 Bar	5568 Psi g	282 Bar	4075 Psi g



**CAST STEEL SWING
CHECK VALVES
PRESSURE SEAL COVER
ASME B16.34**

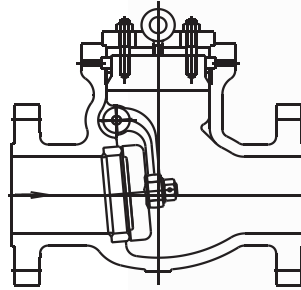

PRESSURE SEAL BONNET DESIGN

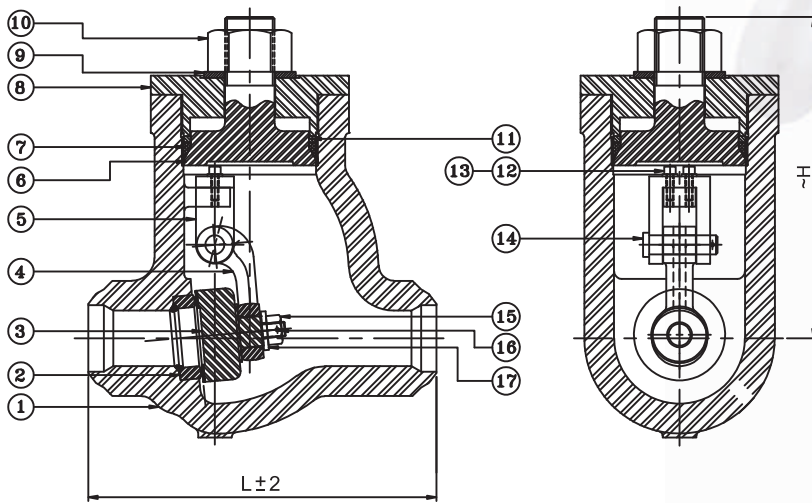

STANDARD MATERIAL COMBINATION

P. NO.	PART DESCRIPTION	Carbon steel to ASTM		Alloy steel to ASTM					Stainless steel to ASTM			
		Type WCB	Type LCB	Type WC1	Type WC6	Type WC9	Type C5	Type C12	Type CF8	Type CF8M	Type CF3	Type CF3M
1	BODY	A216 WCB	A352 LCB	A217 WC1	A217 WC6	A217 WC9	A217 C5	A217 C12	A351 CF8	A351 CF8M	A351 CF3	A351 CF3M
2	DISC	A216 WCB	A352 LCB	A217 WC1	A217 WC6	A217 WC9	A217 C5	A217 C12	A351 CF8	A351 CF8M	A351 CF3	A351 CF3M
4	HING	A216 WCB	A352 LCB	A217 WC1	A217 WC6	A217 WC9	A217 C5	A217 C12	A351 CF8	A351 CF8M	A351 CF3	A351 CF3M
5	FORK	A216 WCB	A352 LCB	A217 WC1	A217 WC6	A217 WC9	A217 C5	A217 C12	A351 CF8	A351 CF8M	A351 CF3	A351 CF3M
6	BONNET	A216 WCB	A352 LCB	A217 WC1	A217 WC6	A217 WC9	A217 C5	A217 C12	A351 CF8	A351 CF8M	A351 CF3	A351 CF3M
7	PRESSURE SEAL GASKET	Graphoil										
8	COVER	A216 WCB	A352 LCB	A217 WC1	A217 WC6	A217 WC9	A217 C5	A217 C12	A351 CF8	A351 CF8M	A351 CF3	A351 CF3M
9	WASHER	Carbon Steel										
10	NUTS	A194 2H	A194 Gr.4	A194 Gr.4	A194 Gr.4	A194 Gr.4	A194 Gr.4	A194 Gr.4	A194 Gr.8	A194 Gr.8	A194 Gr.8	A194 Gr.8
11	PRESSURE RING	A216 WCB	A352 LCB	A217 WC1	A217 WC6	A217 WC9	A217 C5	A217 C12	A351 CF8	A351 CF8M	A351 CF3	A351 CF3M
12	FORK NUT	Stainless Steel										
14	HING PIN	Stainless Steel										
15	DISC NUT	Stainless Steel										
16	LOCKING PIN	Stainless Steel										
17	WASHER	Stainless Steel										

NOTE: The above data is subject to change without notice due to our continuing product improvement program.



CAST STEEL SWING CHECK VALVES

PRESSURE SEAL COVER ASME B16.34

•All dimensions in mm

DIMENSIONAL DATA CLASS-900

DN	40	50	80	100	150	200	250	300	350	400
NPS	1 ½	2	3	4	6	8	10	12	14	16
L	305	368.3	381	457.2	609.6	736.6	838.2	965.2	1029	1130
L1	305	368.3	381	457.2	609.6	736.6	838.2	965.2	1029	1130
L2	305	672	384	460	613	740	841	968	1039	1140
φD	178	216	241.3	292.1	381	470	546.1	609.6	641.4	704.9
T	31.8	38.1	38.1	44.5	55.6	63.5	69.9	79.4	88.9	88.9
K(PCD)	124	165.1	190.5	235	317.5	393.7	469.9	533.4	558.8	616
n	4	08	08	08	12	12	16	20	20	20
φd	28.6	25.4	25.4	31.8	31.8	38.1	38.1	38.1	41.1	44.4
H	188	257	302	340	419	430	550	645	641	780
φb	38	47.5	73	98.3	146	190.5	238	283	311	356
Aprox.wt. ^	47.7	94.45	128	214.5	388.5	645	1431	1790	2464	3080

DIMENSIONAL DATA CLASS-1500

DN	50	80	100	150	200	250	300	350
NPS	2	3	4	6	8	10	12	14
L	368.3	470	546	705	832	990.6	1130.3	1257.3
L1	368.3	470	546	705	832	990.6	1130.3	1257.3
L2	371	473	549	711	842	1001	1147	1277
φD	216	266.7	311.1	393.7	482.6	584.2	673.1	749.3
T	38.1	47.7	54	82.6	92.1	108	123.9	133.4
K(PCD)	165.1	203.2	241.3	317.5	393.7	482.6	571.5	635
n	08	08	08	12	12	12	16	16
φd	25.4	31.8	35	38.1	44.5	50.8	53.8	60.4
H	300	450	500	600	700	800	950	1020
φb	48	70	92	137	178	222	264	289
Aprox.wt. ^	72	104.8	128.6	330.8	----	----	----	----

DIMENSIONAL DATA CLASS-2500

DN	50	80	100	150	200	250	300
NPS	2	3	4	6	8	10	12
L	450	578	673	914	1022	1270	1422
L1	453	584	683	927	1038	1292	1444
φD	235	304.8	355.6	482.6	552.5	673.1	762
T	50.9	66.7	76.2	108	127	165.1	184.2
K(PCD)	171.5	228.6	273	368.3	438.1	539.8	619.2
n	08	08	08	08	12	12	12
φd	28.4	35	41.1	53.8	53.8	66.5	73.1
H	357	500	530	670	730	810	970
φb	38	57	73	111	146	184	219
Aprox.wt. ^	45	78	120	295	450	865	1075

NOTE: The above data is subject to change without notice due to our continuing product improvement program. (^WEIGHT GIVEN IN KGS)

NOTE: Flanges as per ASME B16.5. Butt Weld Ends as per ANSI B 16.25.

TEST PRESSURES

CLASS	SHELL TEST (HYDROSTATIC)		SEAT TEST HYDROSTATIC	
	900	230 Bar	3350 Psi g	169 Bar
1500	384 Bar	5568 Psi g	282 Bar	4075 Psi g
2500	639 Bar	9372 Psi g	469 Bar	6785 Psi g

NOTE: The above data is subject to change without notice due to our continuing product improvement program.

*other trim combination can be given



CAST STEEL HORIZONTAL CHECK VALVES BS: 5160 / DIN: 2401

SPECIFICATIONS

BOLTED COVER, FLANGES ENDS
AS PER DIN STD 2545 : PN 40 (R.F.)

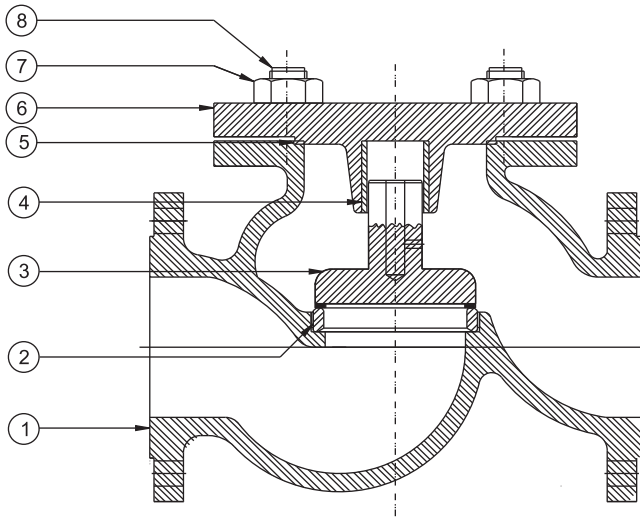

STANDARD MATERIAL COMBINATION

P.NO.	DESCRIPTION	MATERIALS	SPECIFICATIONS
1.	BODY	C.S.	ASTMA 216 Gr. WCB
2.	BODY SEAT RING (HB 250 Min.)	13% Cr. STEEL	ASTMA 182 Gr. F6a or its Eq.
3.	DISC	C.S.	ASTMA 216 Gr. WCB
4.	BUSH	13% Cr. STEEL	ASTMA 182 Gr. F6a or its Eq.
5.	GASKET	S.S. (TYPE-304) SPIRAL WOUND GRAPHIOL FILLED	
6.	COVER	C.S.	ASTMA 216 Gr. WCB
7.	NUTS	H.T. STEEL	ASTMA 194 Gr.2H
8.	STUDS	ALLOY STEEL	ASTMA 193 Gr.B7

NOTE: The above data is subject to change without notice due to our continuing product improvement program.



CAST STEEL HORIZONTAL CHECK VALVES BS: 5160 / DIN: 2401

SPECIFICATIONS

BOLTED BONNET, FLANGES ENDS
AS PER DIN STD 2545 : PN 40 (R.F.)

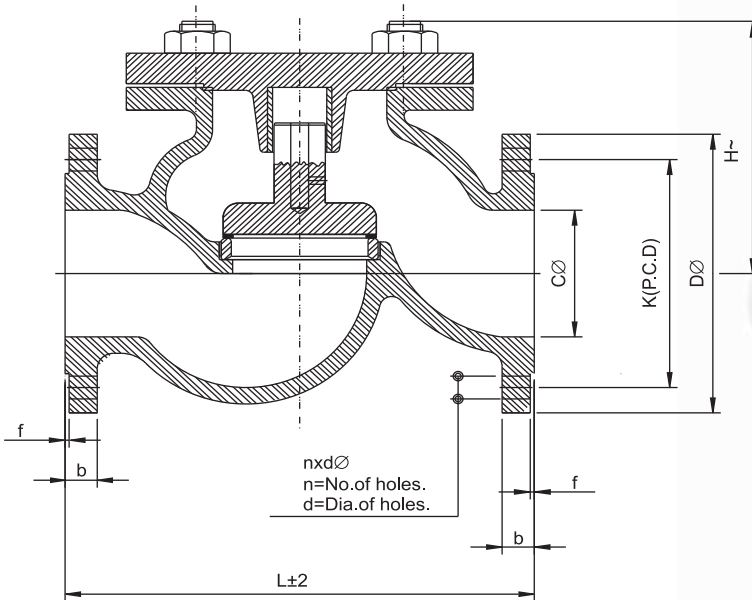

•All dimensions in mm

PRESSURE / TEMPERATURE RATINGS TO BS 5160

NOMINAL PRESSURE	MAX. PERMISSIBLE GAUGE WORKING PRESSURE °C						
	10 TO 120°C	200°C	250°C	300 °C	350 °C	400 °C	425 °C
PN 40	40 bar	40bar	38bar	33bar	28bar	23bar	20bar

DIMENSIONAL DATA

DN NPS	15 1/2'	20 3/4"	25 1"	32 1-1/4"	40 1-1/2"	50 2"	65 2-1/2"	80 3"	100 4"	125 5"	150 6"	200 8"
L	130	150	160	180	200	230	290	310	350	400	480	600
~H	82	84	92	102	120	138	150	185	192	228	263	316
∅C	15	20	25	32	40	50	65	80	100	125	150	200
∅D	95	105	115	140	150	165	185	200	235	270	300	375
b	16	18	18	18	18	20	22	24	24	26	28	34
f	2	2	2	2	3	3	3	3	3	3	3	3
K	65	75	85	100	110	125	145	160	190	220	250	320
n	4	4	4	4	4	4	8	8	8	8	8	17
∅d	14	14	14	18	18	18	18	18	22	26	26	30
Aprox. Wt. ^	4	6	7.6	11	13.1	23.2	31.4	43.9	65.7	109	175.4	272

TEST PRESSURES

NOMINAL PRESSURE RATING	SHELL TEST (HYDROSTATIC)	SEAT TEST (HYDROSTATIC)
PN 40	60 bar	40 bar

NOTE: The above data is subject to change without notice due to our continuing product improvement program. (^WEIGHT GIVEN IN KGS.)



General Description



BALL VALVE

Ball valves with standard materials are low cost, compact, lightweight, easy to install, and easy to operate. They offer full flow with minimum turbulence and can balance or throttle fluids. Typically, ball valves move from closed to full open in a quarter of a turn of the shaft and are, therefore, referred to as quarter turn ball valves. Low torque requirements can permit ball valves to be used in quick manual or automatic

operation, and these valves have a long reliable service life. Ball valves can be full ball.

Full ball valves employ a complete sphere as the flow controlling member. They are of rotary shaft design and include a flow passage. There are many varieties of the full ball valves, with a single piece ball and shaft to reduce torque requirements and lost motion.



CAST STEEL FIRE SAFE BALL VALVE

GENERAL FEATURES

- **FULL BORE** : PROVIDE EXTREME LOW PRESSURE LOSS
- **SPLIT BODY CONSTRUCTION** : EASY MAINTENANCE
- **SIDE ENTRY DESIGN**
- **BLOW OUT PROOF STEM** : PROVIDES BEST POSSIBLE STEM SEALING ARRANGEMENT
- **FLOATING BALL DESIGN** : ENSURES HIGH SEALING EFFICIENCY AT DIFFERENT WORKING PRESSURE
- **ANTISTATIC DEVICE** : GIVES ELECTRIC CONTINUITY BETWEEN BODY & BALL THROUGH STEM
- **PRESSURE RELIEVING HOLE** : TO AVOID OVER PRESSURE IN THE CAVITY BETWEEN THE BALL & BODY
- **ASBESTOS FREE**
- **FIRE SAFE CERTIFIED**
- **SECONDARY METAL SEALING** : REDUCES LEAKAGE THROUGH THE JOINTS DURING FIRE
- **ENDURANCE TEST** : WITNESSED & CERTIFIED FOR 1,00,000 CYCLE OPERATION BY LLOYD'S REGISTER QUALITY ASSURANCE.

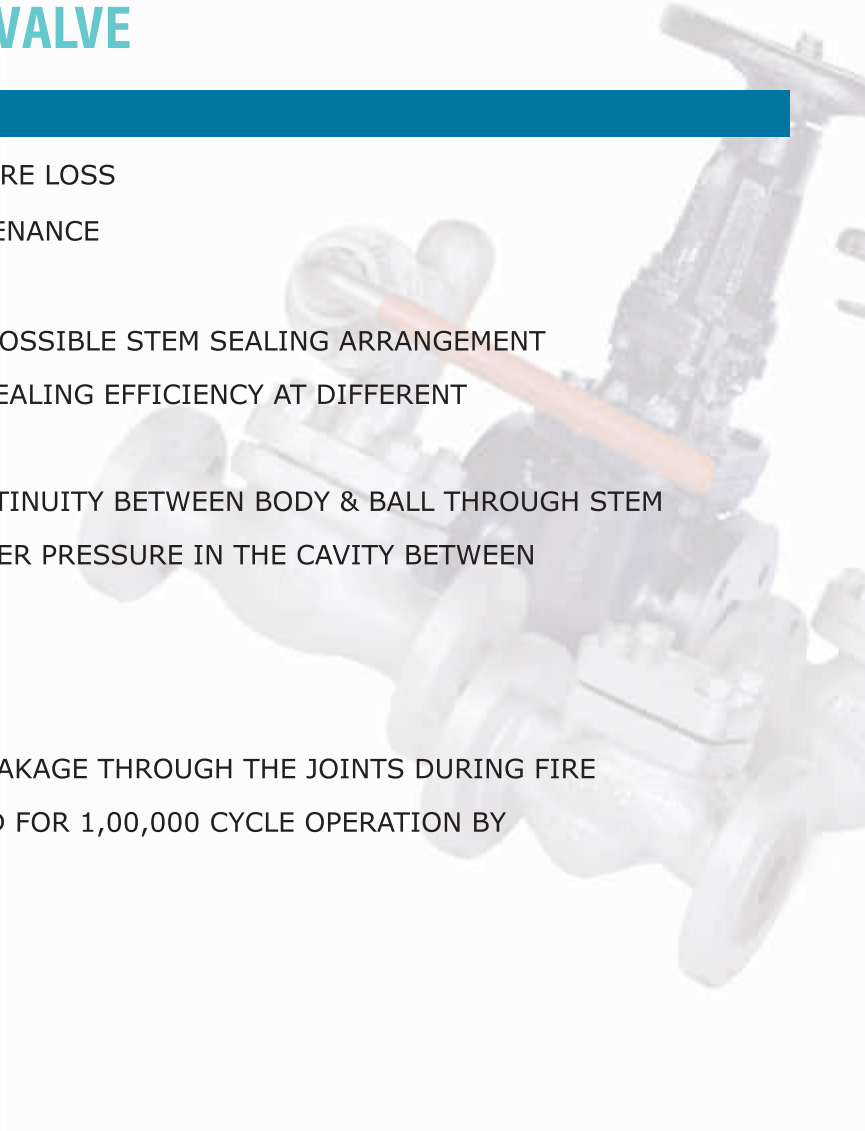

DESIGN STANDARDS:

VALVES DESIGN	API 6D/ANSI B16.34/BSEN 17292
FLANGES	ASME B16.5 RAISED FACE
FACE TO FACE	ASME B16.10/API6D
PRESSURE TESTING	API 598/BSEN-12266-1
FIRE SAFE TEST	API 607
ACTUATOR MOUNTING FLANGE	ISO 5210



CAST STEEL FIRE SAFE-BALL VALVES

BSEN ISO-17292, API-6D

SPECIFICATIONS

TWO PIECE DESIGN,
FULL BORE, SPLIT
BODY, SIDE ENTRY,
BLOW OUT PROOF
STEM & FLOATING
BALL DESIGN

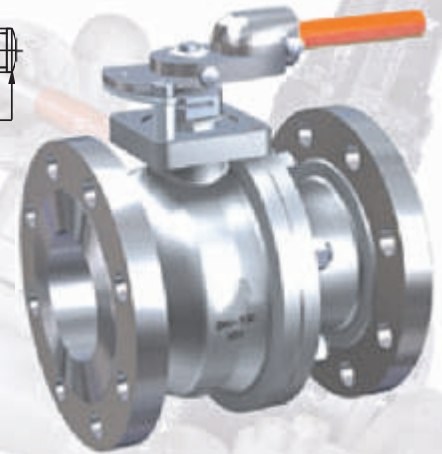
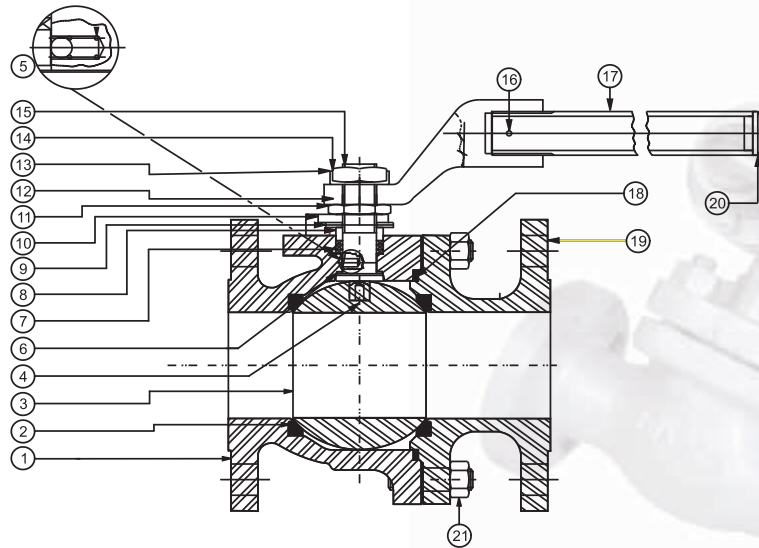

STANDARD MATERIAL COMBINATION

P. NO.	PART DESCRIPTION	MATERIALS SPECIFICATION		
		WCB	CF8	CF8M
1	BODY	ASTM A216 Gr. WCB	ASTM A351 Gr. CF8	ASTM A351 Gr. CF8M
2	SEAT	VIRIGIN UNFILLED OIL FREE PTFE		
3	BALL	ASTM A351 CF8	ASTM A351 Gr. CF8	ASTM A351 Gr. CF8M
4	ANTISTATIC BALL	S.S. 316	S.S. 316	S.S. 316
5	SPRING	BS 2056 EN 58A	BS 2056 EN 58A	BS 2056 EN 58A
6	STEM SEAL	VIRIGIN UNFILLED OIL FREE PTFE (GRAPH OIL FOR FIRE SAFE)		
7	GLAND PACKING	VIRIGIN UNFILLED OIL FREE PTFE (GRAPH OIL FOR FIRE SAFE)		
8	GLAND	ASTM A276 TYPE 410	ASTM A276 TYPE 304	ASTM A276 TYPE 316
9	DISC SPRING (BLACKENED)	BS 970 EN 42J		
10	STOPPER PLATE (Zn. Plated)	IS 2062 Gr.B	IS 2062 Gr. B	IS 2062 Gr.B
11	STEM NUT (Zn. Plated)	ASTM A194 Gr. 2H	S.S 304	S.S 316
12	LEVER HOLDER (Bl. Plated)	ASTM A216 Gr. WCB/ IS 2108 Gr. BM 290	ASTM A216 Gr. WCB/ IS 2108 Gr. BM 290	ASTM A216 Gr WCB/ IS 2108 Gr. BM 290
13	LOCKING WASHER	S.S 304	S.S 304	S.S 316
14	LEVER NUT (Zn. Plated)	S.S 410	S.S 304	S.S 316
15	STEM	ASTM A276 TYPE410	ASTM A276 TYPE304	ASTM A276 TYPE316
16	PIN	CARBON STEEL	CARBON STEEL	CARBON STEEL
17	LEVER PIPE	ASTMA 106 Gr.B	ASTMA 106 Gr.B	ASTMA 106 Gr. B
18	GASKET	SPIRAL WOUND SS-304 WITH GRAPHOIL FILLED		
19	BODY CONNECTOR	ASTM A216 Gr WCB	ASTM A351Gr. CF8	ASTM A351 Gr.CF8M
20	CAP	LDPE	LDPE	LDPE
21	STUDS & NUTS	ASTM A193 Gr. B7& ASTM A194 Gr. 2H	ASTM A193 Gr. B8 & ASTM A194 Gr. 8	ASTM A193 Gr. B8 & ASTM A194 Gr. 8

NOTE: The above data is subject to change without notice due to our continuing product improvement program. Other MOC & Trim Combination can be provided on request.



CAST STEEL FIRE SAFE-BALL VALVES BSEN ISO-17292, API-6D

SPECIFICATIONS:-

TWO PIECE DESIGN, FULL BORE, SPLIT BODY, SIDE ENTRY,
BLOW OUT PROOF STEM & FLOATING BALL DESIGN.

FACE TO FACE: ASME B 16.10 / API 6D

FLANGE STANDARD : 16.5 RAISED FACE

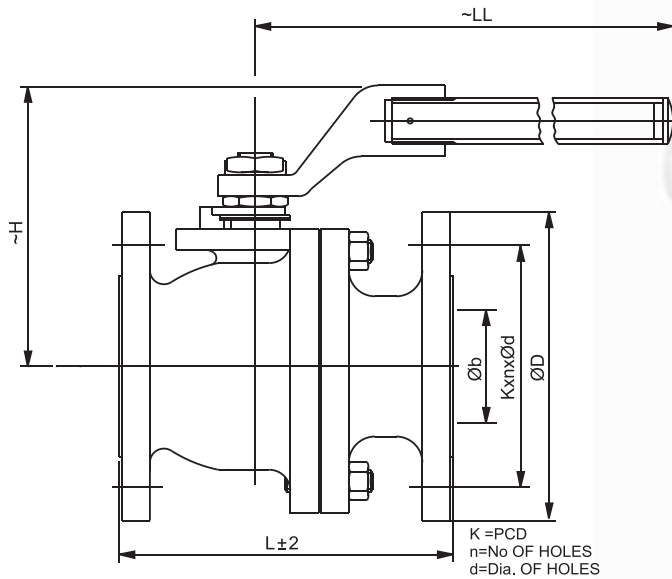

NOTE: ACTUATOR & GEAR OPERATED VALVES
CAN ALSO BE SUPPLIED ON DEMAND.

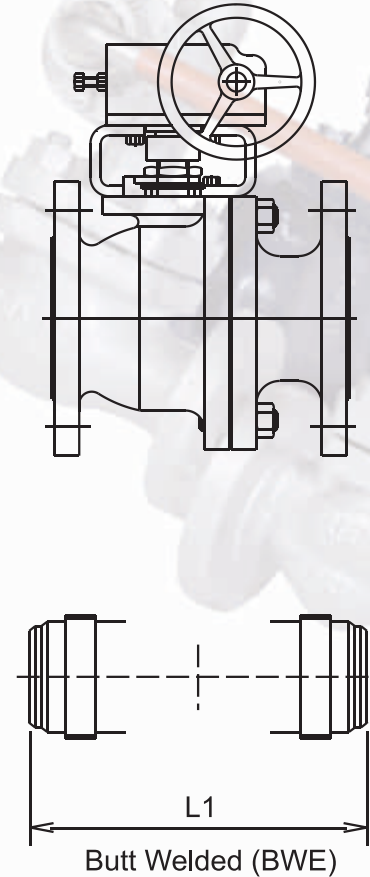

• All dimensions in mm

DIMENSIONAL DATA CLASS-150

DN	15	20	25	32	40	50	65	80	100	150
NPS	1/2"	3/4	1	1 1/4	1 1/2	2	2 1/2	3	4	6
L /L1	108	117	127	140	165	178	190	203	229	394
ØD	90	100	110	115	125	150	180	190	230	280
T	11.2	11.2	11.2	12.7	14.3	15.9	17.5	19	23.8	25.4
K (PCD)	60.3	69.9	79.4	88.9	98.4	120.7	139.7	152.4	190.5	241.3
n	04	04	04	04	04	04	04	04	08	08
Ød	15.7	15.7	15.7	15.7	15.7	19.1	19.1	19.1	19.1	22.2
LL	125	175	175	225	225	225	400	400	460	775
Aprox.wt. ^	3.400	4.5	5.400	8.400	9.000	12.000	18.000	23.5	50	102

NOTE: The above data is subject to change without notice due to our continuing product improvement program. (^ WEIGHT GIVEN IN KGS)



CAST STEEL FIRE SAFE-BALL VALVES BSEN ISO-17292, API-6D

DIMENSIONAL DATA CLASS-300

•All dimensions in mm

DN	15	20	25	32	40	50	65	80	100	150
NPS	½"	¾	1	1 ¼	1 ½	2	2 ½	3	4	6
L /L1	140	152	165	178	190	216	241	282	305	403
φD	95	115	125	135	155	165	190	210	255	320
T	14.2	15.8	17.5	19.1	20.6	22.2	25.4	28.6	31.8	36.5
K(PCD)	66.7	82.6	88.9	98.4	114.3	127	149.2	168.3	200	269.9
n	04	04	04	04	04	08	08	08	08	12
φd	15.9	19.1	19.1	19.1	22.3	19.1	22.3	22.3	22.3	22.3
LL	125	175	175	225	225	225	400	400	460	775
Aprox.wt. ▲	3.525	4.900	7.9	9.8	12	19.5	24.7	39	67	132

DIMENSIONAL DATA CLASS-600

DN	15	20	25	32	40	50	65	80	100	150
NPS	½"	¾	1	1 ¼	1 ½	2	2 ½	3	4	6
L/L1	165	190	216	229	241	292	330	356	432	559
φD	95	115	125	135	155	165	190	210	275	355
T	14.2	15.8	17.5	20.6	22.2	25.4	28.6	31.8	38.1	47.6
K (PCD)	66.7	82.6	88.9	98.4	114.3	127	149.2	168.3	216.9	292.1
n	04	04	04	04	04	08	08	08	08	12
φd	15.9	19.1	19.1	19.1	22.3	19.1	22.3	22.3	25.4	28.6
LL	125	175	175	225	225	225	400	400	460	775
Aprox.wt. ▲	--	--	12	15	19	23.5	34.5	43	101	130

NOTE: The above data is subject to change without notice due to our continuing product improvement program. (▲WEIGHT GIVEN IN KGS)

TEST PRESSURES

CLASS	SHELL TEST (HYDROSTATIC)		SEAT TEST			
			HYDROSTATIC		PNEUMATIC	
150	30 Bar	435 Psi g	22 Bar	319 Psi g	6.9 bar	100 Psi g
300	77 Bar	1102 Psi g	57 Bar	780 Psi g	6.9 bar	100 Psi g
600	154 Bar	2175 Psi g	77 Bar	1080 Psi g	6.9 bar	100 Psi g



CAST STEEL GLANDLESS PISTON VALVE

WORKING PRINCIPLE:-

The piston Valve comprises stainless steel piston, two resilient valve rings, a valve bush and belleville washer to take care of pressure and temperature fluctuations automatically. The sealing is achieved by the contact between the outer surface of the piston and the inner surfaces of the sealing rings. The belleville washers, however maintain constant pressure on the resilient valve rings and automatically compensate for any thermal expansions that may occur.

SALIENT FEATURES OF PISTON VALVE:-

- *TIGHT SHUT -OFF: The valve is tight shut off at both low high differential pressure.
- *NO JAMMING: Scalings and solids do not cause valve jamming.
- *GLAND LESS VALVE: No gland packing, does not contaminate with environment.
- *HIGH CYCLE SERVICE: Piston is Unexposed to media, foreign matters are swept away by descending piston, so the valve tightness remains even when the valve is operated continuously over a long period.
- *MAINTENANCE FREE: Replacement of rings makes the valve as new one Lapping/grinding maintenance can be carried out without removing the valve from the pipe line.
- *LOW TORQUE: Because the sealing is effected by resilient valve rings. Lower torque means smaller actuators-and savings in both cost and space.
- *BELLEVILLE WASHERS: Designs incorporates Belleville washers below bonnet bolting so that the Valve remains Pressure tight during thermal expansion.
- *OPEN SHUT INDICATOR: To identify the position (close or open) of valve. To have predetermined controlled flow with externally visible indicator.



CAST STEEL GLANDLESS PISTON VALVE

SPECIFICATIONS

STRAIGHT PATTERN, BOLTED BONNET RISING STEM, FLANGED ENDS AS PER DIN 2533 OR DIN 2545-AS APPLICABLE

CERTIFICATE

ITEMS CAN BE SUPPLIED WITH CERTIFICATE OF MANUFACTURERS & TEST ON FORM III C AS PER REGULATION 269 OF IBR

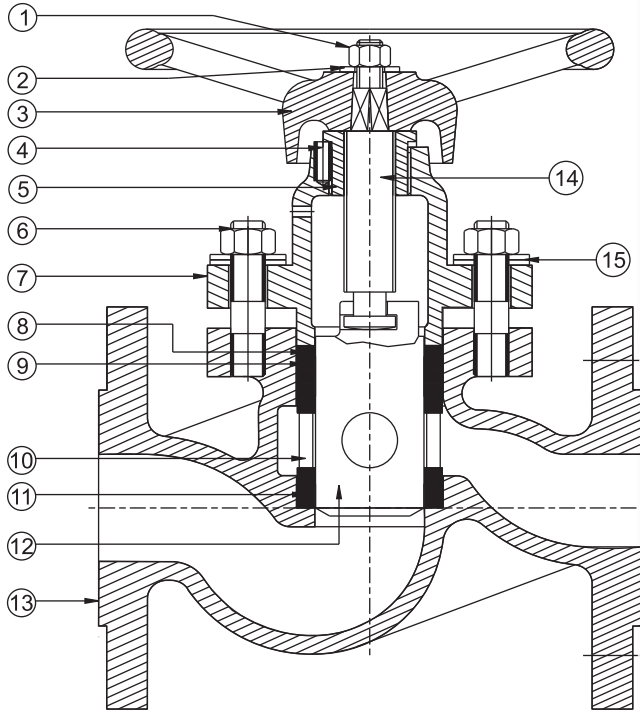

STANDARD MATERIAL COMBINATION

P.NO.	DESCRIPTION	MATERIALS SPECIFICATIONS
1.	NUT	CARBON STEEL B.S. 916:53
2.	WASHER	CARBON STEEL IS 2062:92 Gr. A
3.	HANDWHEEL	C.S. ASTM A216:93 Gr. WCB
4.	LOCKING SCREW	CARBON STEEL B.S. 916:53
5.	YOKE BUSH	AL. BRONZE/NODULAR IRON BS 2874:86 CA104/ASTM A439:83 Gr.D2
6.	STUDS & NUTS	ALLOY STEEL H.T. STEEL ASTM A193:99 Gr. B7 ASTM A194:98 Gr.2H
7.	BONNET	C.S. ASTM A216:93 Gr. WCB
8.	RING	13% Cr. STEEL ASTM A182:99 Gr. F6a
9.	RING	MOULDED GRAPHOIL SUITABLE FOR Max. DESIGN TEMP. 475°C
10.	VALVE SEAT	13% Cr. STEEL ASTM A182:99 Gr. F6a
11.	RING	MOULDED GRAPHOIL SUITABLE FOR Max. DESIGN TEMP. 475°C
12.	PISTON	13% Cr. STEEL ASTM A182:99 Gr. F6a
13.	BODY	C.S. ASTM A216:93 Gr. WCB
14.	STEM	13% Cr. STEEL ASTM A182:99 Gr.F6a/ASTM A276:98 TYPE 410
15.	BELLEVILLE WASHER	STEEL -----

NOTE: The above data is subject to change without notice due to our continuing product improvement program.



CAST STEEL GLANDLESS PISTON VALVE

SPECIFICATIONS

BOLTED BONNET, INSIDE SCREW, RISING STEM, FLANGES
AS PER DIN 2545

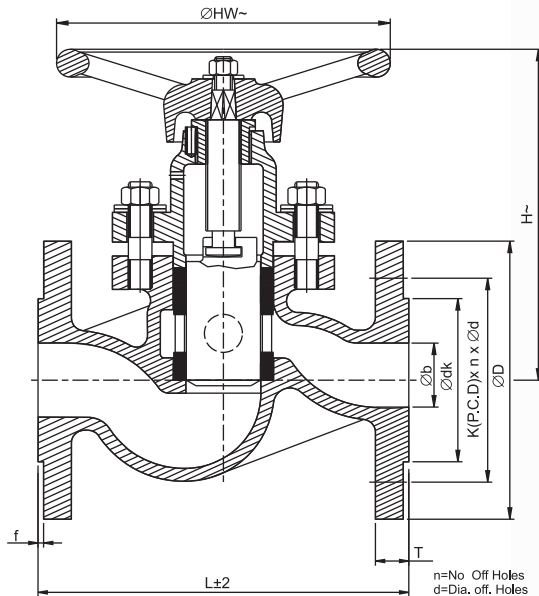

•All dimensions in mm

PRESSURE / TEMPERATURE RATINGS

NOMINAL PRESSURE	MAX. PERMISSIBLE GAUGE WORKING PRESSURE °C									
	10 TO 120°C	150°C	180°C	200 °C	220 °C	250 °C	300 °C	350 °C	400 °C	425°C
PN 40	40 bar	40bar	40bar	40bar	---	38bar	33bar	28bar	23bar	20bar

DIMENSIONAL DATA

DN NPS	15 1/2'	20 3/4"	25 1"	32 1-1/4"	40 1-1/2"	50 2"	65 2-1/2"	80 3"	100 4"
L	130	150	160	180	200	230	290	310	350
T	16	18	18	18	18	20	22	24	24
f	2	2	2	2	3	3	3	3	3
Øb	15	20	25	32	40	50	65	80	100
H	115	125	130	155	185	190	250	295	315
ØHW	127	127	140	160	180	200	265	265	300
Ødk	45	58	68	78	88	102	122	138	162
ØD	95	105	115	140	150	165	165	200	235
K	65	75	85	100	110	125	145	160	190
n	4	4	4	4	4	4	8	8	8
Ød	14	14	14	18	18	18	18	18	22
Aprox. Wt. ▲	3.5	4	4.5	8.8	13	19.5	32	40	53

TEST PRESSURES

NOMINAL PRESSURE RATING	SHELL TEST (HYDROSTATIC)	SEAT TEST (HYDROSTATIC & 6:9 BAR (AIR))
PN 40	60 bar	40 bar

NOTE: The above data is subject to change without notice due to our continuing product improvement program. (▲WEIGHT GIVEN IN KGS)



CAST STEEL LUBRICATED TAPER PLUG VALVES

SPECIFICATIONS

C.S. LUBRICATED TAPER PLUG VALVES, SHORT PATTERN, FLANGED ENDS.

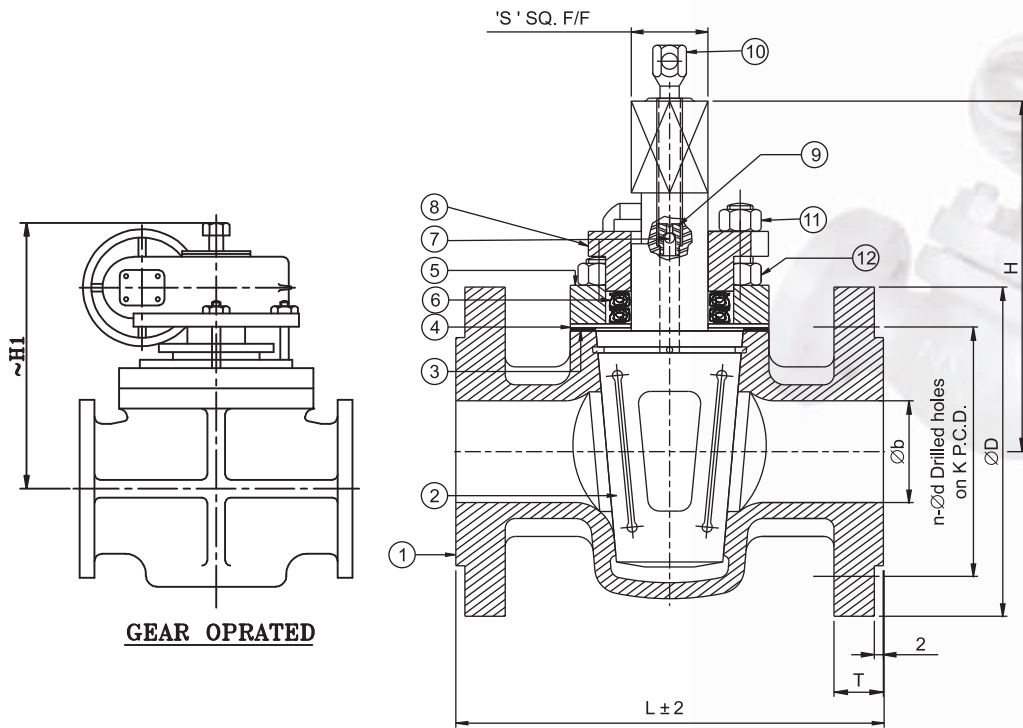

STANDARD MATERIAL COMBINATION

P.NO.	DESCRIPTION	MATERIALS	SPECIFICATIONS
1.	BODY	C.S.	ASTMA216 Gr.WCB
2.	PLUG	C.S.	ASTMA216 Gr.WCB
3.	GASKET	C.A.F./GRAFOIL	BS 1832
4.	SHIM	S.S.	TYPE 304
5.	COVER	C.S.	ASTMA 216 Gr.WCB
6.	PACKING	TO SUIT SERVICE CONDITIONS	
7.	CHECK VALVE	CARBON STEEL	-----
8.	GLAND	C.S.	ASTMA 216 Gr.WCB
9.	LUBRICANT	TO SUIT THE SERVICE CONDITIONS	
10.	LUBRICANT SCREW	CARBON STEEL	-----
11.	STUDS & NUTS FOR BODY & COVER	ALLOY STEEL & H.T. STEEL	ASTMA 193 Gr. B7 & ASTMA 194 Gr. 2H
12.	STUDS & NUTS	ALLOY STEEL & H.T. STEEL	ASTMA 193 Gr.B7 & ASTMA 194 Gr.2H

NOTE: The above data is subject to change without notice due to our continuing product improvement program.

The purchases should state in the enquiry or order if the valves is required to be filled with lubricant/sealant to meet particular by service conditions. Otherwise the manufacturer will supply valves filled with the normal assembly grade lubricant.



CAST STEEL LUBRICATED TAPER PLUG VALVES

DIMENSIONAL DATA CLASS-150

DN NPS	25 1"	40 1-1/2"	50 2"	65 2-1/2"	80 3"	100 4"	150 6"	200 8"
L	140	165	178	190	203	229.0	267	292
H	123	155	153	173	208	268	319	398
C	25	38	51	63.5	76	101.5	150	203
S	22	27	27	32	38	47	50.8	58.7
ØD	108	127	152.5	178	190.5	229	279.5	343
Øb	11.2	14.2	15.8	17.5	19.1	24	25.4	28.5
R	50.8	73.2	92	104.6	127	157.2	216	269.7
K	79.2	98.5	120.7	139.7	152.4	190.5	241.3	298.5
n	4	4	4	4	4	8	8	8
Ød	15.7	15.7	19.1	19.1	19.1	19.1	22.3	22.3
Aprox. Wt. [▲]	10.5	14.1	21.6	29	36	58.8	115.8	154

DIMENSIONAL DATA CLASS-300

DN NPS	25 1"	40 1-1/2"	50 2"	65 2-1/2"	80 3"	100 4"	150 6"	200 8"
L	158.8	190.5	216	241.3	282.6	304.8	403.2	419
H	120	155	176	195	230	250	285	--
C	25.4	38	50.8	64	76.2	102	152.4	203.2
S	22.2	27	31.8	36.5	41.3	47.6	50.8	--
ØD	124	155.5	165	190.5	209.5	254	317.5	381
Øb	17.5	20.5	22.3	25.4	28.4	31.8	36.8	41.2
R	50.8	73	92	104.6	127	157.2	216	269.7
K	89	114.3	127	149.3	168	200	269.7	330.2
n	4	4	8	8	8	8	12	12
Ød	19	22.8	19	223	223	223	223	254
Aprox. Wt. [▲]	-	16.2	34.2	42	54.5	83.9	135	160.7

NOTE: The above data is subject to change without notice due to our continuing product improvement program. (▲WEIGHT GIVEN IN KGS)

Flanges as per ASME B16.5. Butt Weld Ends as per ANSI B 16.25.

TEST PRESSURES

CLASS	SHELL TEST (HYDROSTATIC)		SEAT TEST	
			HYDROSTATIC	
150	30 Bar	435 Psi g	22 Bar	319 Psi g
300	77 Bar	1102 Psi g	57 Bar	780 Psi g



Cast Steel Dual Plate Check Valve

Technical characters and selection of dual Plate Check Valves

The concept of the dual plate check valves means a lot of advantages compared with the other conventional check valves.

The most important are:

- Notable reduction of the valves weight
- Reduced water-hammer effect due to action of the spring force
- Low stress (fatigue) of the plates because during closure the plates do not produce force on the shaft.

The mechanism of the dual plate check valves is very simple and reliable for functionality. Since the valve is build with 2 half plates, the weight o these plates does not react on the fluid nor creates friction on the hinge pin because the plates are placed in vertical position. The spring force is creating an anti water hammer effect by helping to close the plates before the flow return.

One of the most important reasons of a check valves is to avoid the negative effects that are created by the reverse flow on the pumps and other elements of the installations.

During a short space of time, after the stopping the impulsive energy, the water column keeps on flowing until the kinetic energy of the fluid disperse due to the internal

friction and gravity, causing the reverse of the flow.

A conventional check valve (swing check valve) possesses a long inertia that allows creating a high velocity of the flow reverse.

The weight of the plate in this type of valve is very elevated. The weight combined with the high reverse flow will create a very high and strong over pressure (water hammer)at moment of closure.

The dual plate check valves have the following advantages on the above mentioned effects. Half plates with reduced weight and short inertia for closing have a reduced slamming (shocking) of the plates on the seat.

One or more springs assure the closing of the plates before the flow reverses. Theoreticaly if the reverse flow is avoided, the effect of over pressure during return will disappear.

The water-hammer is reduced approximate 20% compared with swing check (considering a standard torque spring). The water-hammer can be reduced by adjusting to higher torque springs (quicker closure). However always considering that the pressure drop created by the springs does not have negative influence on the installation.

Difference between Dual Plate Check Valve & Swing Check Valve

Dual Plate Check Valve	Swing Check Valve
<ul style="list-style-type: none"> • Light Weight thus easier handling and self supporting. • More compact & structurally sound design. • Only Check Valve which can be installed for flow upside down due to spring assisted closure. • Low Pressure Drop and reduced Energy Loss Irrespective of Pressure Ratings. • Streamlined flow way. • Efficient and positive sealing under most flow and pressure conditions. Valve closes before flow reversal at zero velocity. • Inherently Non-Slamming. No external devices / attachments required. • Water Hammer almost non-existent. • Long life and trouble-free operation. 	<ul style="list-style-type: none"> • Bulky & voluminous thus cumbersome handling & heavier supporting system. • Large & difficult to analyze from stress concentration points in critical applications due to intricate body shape. • Suitable primarily for horizontal applications. • Not possible. • Significant Pressure Loss and Energy Loss, which is still higher at higher Pressure ratings. • Swing restricted flow path. • Always require reverse flow for closure and back pressure for effective sealing. • External attachment required to counteract slamming. • Water hammer tendency persists. • Seat & Hinge Pin require regular maintenance due to impact loads and wear by rubbing.



CAST STEEL DUAL PLATE CHECK VALVE (WAFER TYPE) (RETAINERLESS DESIGN)

PRODUCT SPECIFICATIONS : API 594

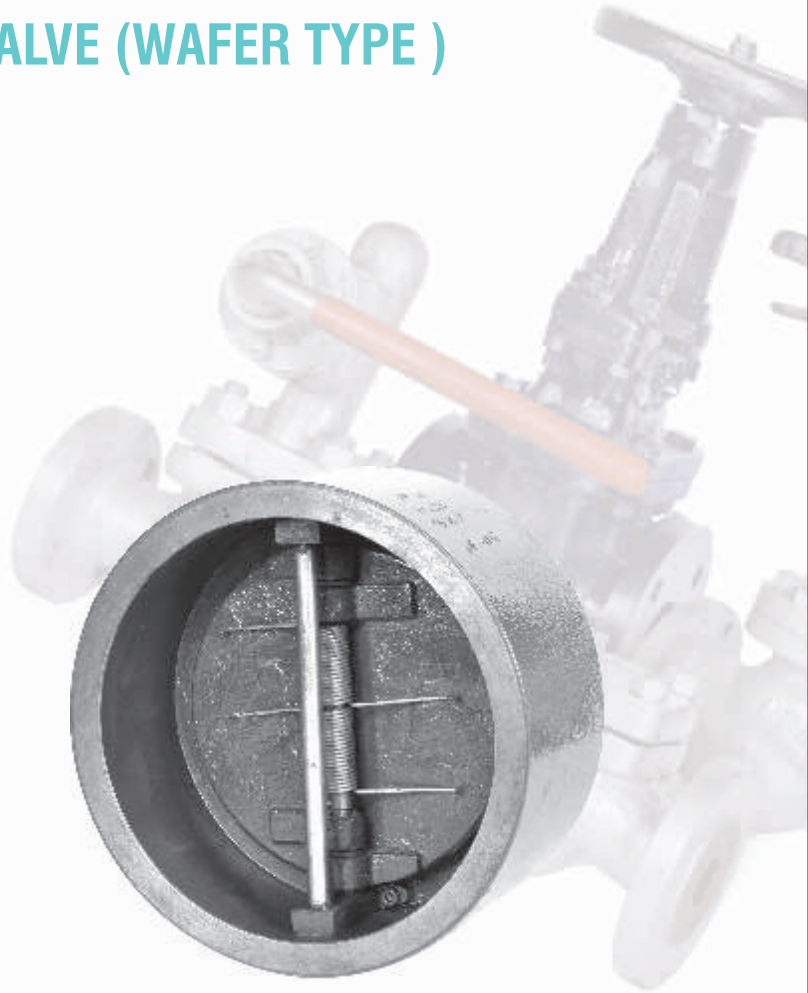
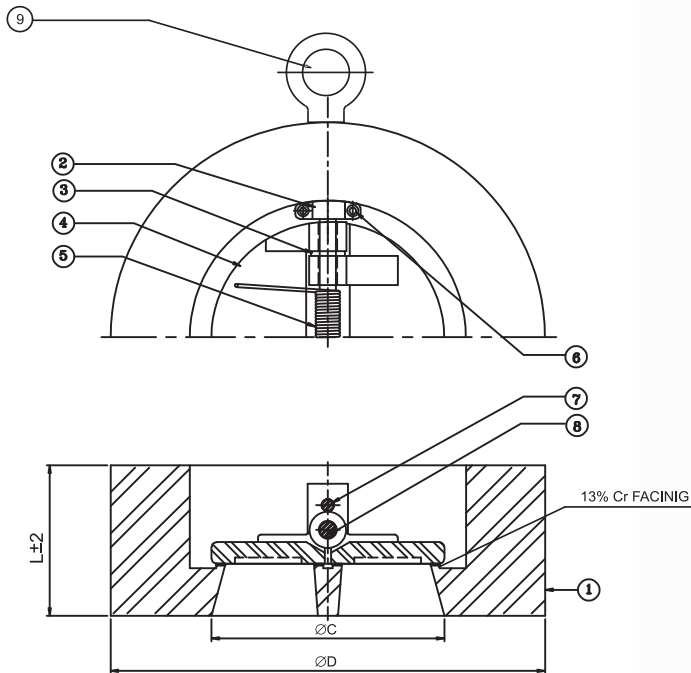

• All dimensions in mm

STANDARD MATERIAL COMBINATION

P. No.	DESCRIPTION	MATERIAL SPECIFICATION				
		WCB	CF8	CF8M	CF3	CF3M
1.	BODY	ASTM A216 Gr. WCB	ASTM A351 Gr. CF8	ASTM A351 Gr. CF8M	ASTM A351 Gr. CF3	ASTM A351 Gr. CF3M
2.	DISC	ASTM A217 Gr. CA15	ASTM A351 Gr. CF8	ASTM A351 Gr. CF8M	ASTM A351 Gr. CF3	ASTM A351 Gr. CF3M
3.	DISC HOLDING PLATE	ASTM A216 Gr. WCB	ASTM A351 Gr. CF8	ASTM A351 Gr. CF8M	ASTM A351 Gr. CF3	ASTM A351 Gr. CF3M
4.	BUSH	ASTM A276 TYPE 304	ASTM A276 TYPE 304	ASTM A276 TYPE 316	ASTM A276 TYPE 304L	ASTM A276 TYPE 316L
5.	SPRING	S.S. 304/INCONEL	SS.304/INCONEL	SS.316/INCONEL	SS.316/INCONEL	SS.316L/INCONEL
6.	L-KEY SCREW	CARBON STEEL	ASTM A276 TYPE 304	ASTM A276 TYPE 316	ASTM A276 TYPE 316	ASTM A276 TYPE 316
7.	STOPPER PIN	ASTM A276 TYPE 410	ASTM A276 TYPE 304	ASTM A276 TYPE 316	ASTM A276 TYPE 304L	ASTM A276 TYPE 316L
8.	DISC HOLDER PIN	ASTM A276 TYPE 410	ASTM A276 TYPE 304	ASTM A276 TYPE 316	ASTM A276 TYPE 304L	ASTM A276 TYPE 316L
9.	EYE BOLT	CARBON STEEL	CARBON STEEL	CARBON STEEL	CARBON STEEL	CARBON STEEL



CAST STEEL DUAL PLATE CHECK VALVE (WAFER TYPE) (RETAINERLESS DESIGN)

TRIM MATERIAL COMBINATION (ON REQUEST)

Trim No.	Seat Ring Face	Wedge Seat Face	Stem	Backseat Bush	Lantern Ring
1	F6a/13%Cr.	F6a/13%Cr.	F6a/AISI410	F6a/AISI410	F6a/AISI410
2	F304	F304	F304/AISI304	F304/AISI304	F304/AISI304
5	STELLITE	STELLITE	F6a/AISI410	F6a/AISI410	F6a/AISI410
8	STELLITE	F6a/13%Cr.	F6a/AISI410	F6a/AISI410	F6a/AISI410
9	MONEL	MONEL	MONEL	MONEL	MONEL
10	F316	F316	F316/AISI316	F316/AISI316	F316/AISI316
12	316+STELLITE	316	F316/AISI316	F316/AISI316	F316/AISI316
13	ALLOY 20	ALLOY 20	ALLOY 20	ALLOY 20	ALLOY 20

NOTE: Other Trim Combination of API 600 Can Be Provided on Request.

DIMENSIONAL DATA CLASS-150

•All dimensions in mm

SIZE DN	50	65	80	100	150	200	250	300	350	400	450	500	600	700	900
L	60	67	73	73	98	127	146	181	184	191	203	219	222	702	914
∅C	50	65	68	100	150	200	250	300	350	400	450	500	600	700	900
∅D	101	119	130	170	214	273	334	403	446	510	545	602	713	1133	1415

DIMENSIONAL DATA CLASS-300

SIZE DN	50	65	80	100	150	200	250	300	350	400	450	500	600	700	900
L	60	67	73	73	98	127	146	181	222	232	264	292	318	292	330
∅C	50	65	68	100	150	200	250	300	350	400	450	500	600	700	900
∅D	107	127	145	177	247	304	358	419	582	436	593	650	771	1032	1122

NOTE: The above data is subject to change without notice due to our continuing product improvement program. (▲WEIGHT GIVEN IN KGS)

TEST PRESSURES

CLASS	SHELL TEST (HYDROSTATIC)		SHELL TEST (HYDROSTATIC)	
	Bar	Psi g	Bar	Psi g
150	30 Bar	435 Psi g	22 Bar	319 Psi g
300	76 Bar	1102 Psi g	55 Bar	780 Psi g



CAST STEEL DUAL PLATE CHECK VALVES (SOLID LUG TYPE) (RETAINERLESS TYPE)

SPECIFICATIONS : API 594

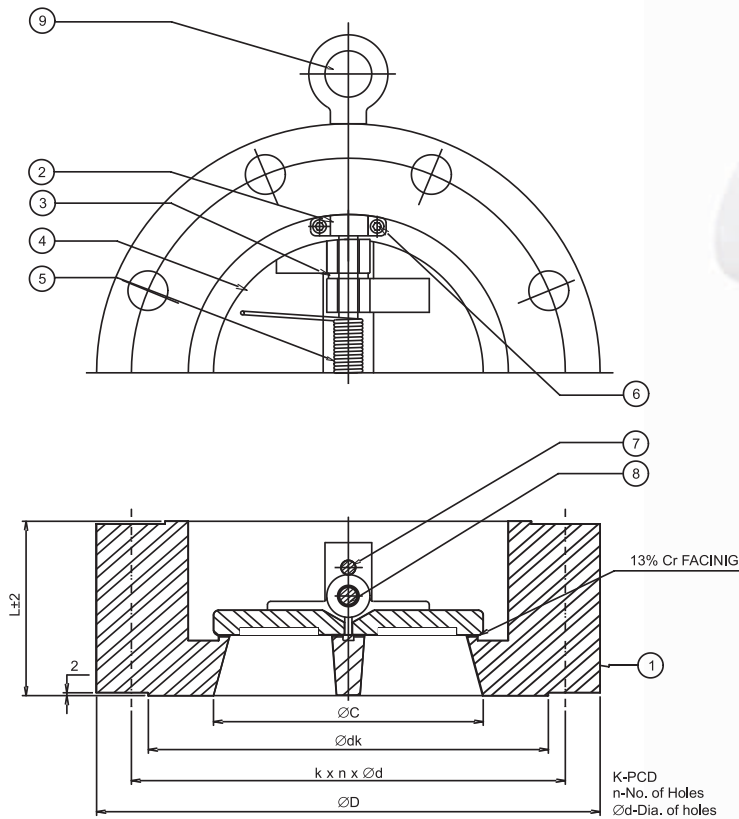

STANDARD MATERIAL COMBINATION

P. No.	DESCRIPTION	MATERIAL SPECIFICATION				
		WCB	CF8	CF8M	CF3	CF3M
1.	BODY	ASTM A216 Gr. WCB	ASTM A351 Gr. CF8	ASTM A351 Gr. CF8M	ASTM A351 Gr. CF3	ASTM A351 Gr. CF3M
2.	DISC	ASTM A217 Gr. CA15	ASTM A351 Gr. CF8	ASTM A351 Gr. CF8M	ASTM A351 Gr. CF3	ASTM A351 Gr. CF3M
3.	DISC HOLDING PLATE	ASTM A216 Gr. WCB	ASTM A351 Gr. CF8	ASTM A351 Gr. CF8M	ASTM A351 Gr. CF3	ASTM A351 Gr. CF3M
4.	BUSH	ASTM A276 TYPE 304	ASTM A276 TYPE 304	ASTM A276 TYPE 316	ASTM A276 TYPE 304L	ASTM A276 TYPE 316L
5.	SPRING	S.S. 304/INCONEL	SS.304/INCONEL	SS.316/INCONEL	SS.316/INCONEL	SS.316L/INCONEL
6.	L-KEY SCREW	CARBON STEEL	ASTM A276 TYPE 304	ASTM A276 TYPE 316	ASTM A276 TYPE 316	ASTM A276 TYPE 316
7.	STOPPER PIN	ASTM A276 TYPE 410	ASTM A276 TYPE 304	ASTM A276 TYPE 316	ASTM A276 TYPE 304L	ASTM A276 TYPE 316L
8.	DISC HOLDER PIN	ASTM A276 TYPE 410	ASTM A276 TYPE 304	ASTM A276 TYPE 316	ASTM A276 TYPE 304L	ASTM A276 TYPE 316L
9.	EYE BOLT	CARBON STEEL	CARBON STEEL	CARBON STEEL	CARBON STEEL	CARBON STEEL



CAST STEEL DUAL PLATE CHECK VALVES (RETAINERLESS LUG TYPE)

TRIM MATERIAL COMBINATION (ON REQUEST)

Trim No.	Seat Ring Face	Wedge Seat Face	Stem	Backseat Bush	Lantern Ring
1	F6a/13%Cr.	F6a/13%Cr.	F6a/AISI410	F6a/AISI410	F6a/AISI410
2	F304	F304	F304/AISI304	F304/AISI304	F304/AISI304
5	STELLITE	STELLITE	F6a/AISI410	F6a/AISI410	F6a/AISI410
8	STELLITE	F6a/13%Cr.	F6a/AISI410	F6a/AISI410	F6a/AISI410
9	MONEL	MONEL	MONEL	MONEL	MONEL
10	F316	F316	F316/AISI316	F316/AISI316	F316/AISI316
12	316+STELLITE	316	F316/AISI316	F316/AISI316	F316/AISI316
13	ALLOY 20	ALLOY 20	ALLOY 20	ALLOY 20	ALLOY 20

NOTE: Other Trim Combination of API 600 Can Be Provided on Request.

DIMENSIONAL DATA CLASS-150

• All dimensions in mm

SIZE DN	50	65	80	100	150	200	250	300	350	400	450	500	600	700	900
L	60	67	73	73	98	127	146	181	184	191	203	219	222	305	368
∅C	50	65	68	100	150	200	250	300	350	400	450	500	600	700	900
∅D	150	180	190	230	280	345	405	485	535	595	635	700	815	837	1057
∅dk	92	104.6	127	157.4	216	269.7	324	381	412.8	470	533.5	584.2	692.2	762	972
k	120.7	139.7	152.4	190.5	241.3	298.5	361.9	431.8	476.2	539.7	577.8	635	749.3	795.3	1009.7
n	4	4	4	8	8	8	12	12	12	16	16	20	20	40	44
∅d	19.1	19.1	19.1	19.1	22.3	22.3	25.4	25.4	28.4	28.4	31.8	31.8	35	22.3	25.4
Aprox. Wt. [▲]	4.51	9.3	19.7	34.3	47.7	86.8	139.4	187	209	243.1	267.3	397	629.2	952.6	-

DIMENSIONAL DATA CLASS-300

SIZE DN	50	65	80	100	150	200	250	300	350	400	450	500	600	700	900
L	60	67	73	73	98	127	146	181	222	232	264	292	318	292	330
∅C	50	65	68	100	150	200	250	300	350	400	450	500	600	700	900
∅D	165	190	210	255	320	380	445	520	585	650	710	775	915	1270	1500
∅dk	92	104.6	127	157.4	216	269.7	324	381	412.8	470	533.5	584.2	692.2	-	-
k	127	149.3	168.1	200.1	269.7	330.2	387.3	450.8	514.3	571.5	628.6	685.8	812.8	-	-
n	8	8	8	8	12	12	16	16	20	20	24	24	24	-	-
∅d	19.1	22.3	22.3	22.3	22.3	25.4	28.4	31.8	31.8	35	35	35	41.1	-	-
Aprox. Wt. [▲]	12.9	15.6	21.2	31.2	36.3	88	159.1	204.6	222.3	258.5	313.5	434.5	663.3	-	-

NOTE: The above data is subject to change without notice due to our continuing product improvement program. (▲WEIGHT GIVEN IN KGS)

TEST PRESSURES

CLASS	SHELL TEST (HYDROSTATIC)		SHELL TEST (HYDROSTATIC)	
	Bar	Psi g	Bar	Psi g
150	30 Bar	435 Psi g	22 Bar	319 Psi g
300	76 Bar	1102 Psi g	55 Bar	780 Psi g



CAST STEEL DUAL PLATE CHECK VALVES (DOUBLE FLANGE TYPE), API 594

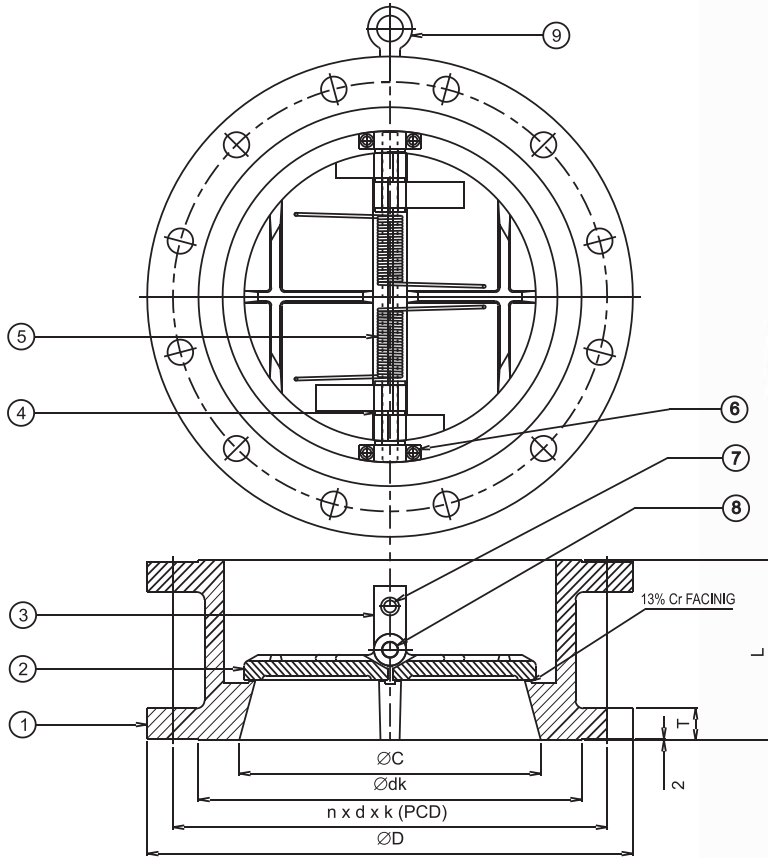

STANDARD MATERIAL COMBINATION

P. No.	DESCRIPTION	MATERIAL SPECIFICATION				
		WCB	CF8	CF8M	CF3	CF3M
1.	BODY	ASTM A216 Gr. WCB	ASTM A351 Gr. CF8	ASTM A351 Gr. CF8M	ASTM A351 Gr. CF3	ASTM A351 Gr. CF3M
2.	DISC	ASTM A217 Gr. CA15	ASTM A351 Gr. CF8	ASTM A351 Gr. CF8M	ASTM A351 Gr. CF3	ASTM A351 Gr. CF3M
3.	DISC HOLDING PLATE	ASTM A216 Gr. WCB	ASTM A351 Gr. CF8	ASTM A351 Gr. CF8M	ASTM A351 Gr. CF3	ASTM A351 Gr. CF3M
4.	BUSH	ASTM A276 TYPE 304	ASTM A276 TYPE 304	ASTM A276 TYPE 316	ASTM A276 TYPE 304L	ASTM A276 TYPE 316L
5.	SPRING	S.S. 304/INCONEL	SS.304/INCONEL	SS.316/INCONEL	SS.316/INCONEL	SS.316L/INCONEL
6.	L-KEY SCREW	CARBON STEEL	ASTM A276 TYPE 304	ASTM A276 TYPE 316	ASTM A276 TYPE 316	ASTM A276 TYPE 316
7.	STOPPER PIN	ASTM A276 TYPE 410	ASTM A276 TYPE 304	ASTM A276 TYPE 316	ASTM A276 TYPE 304L	ASTM A276 TYPE 316L
8.	DISC HOLDER PIN	ASTM A276 TYPE 410	ASTM A276 TYPE 304	ASTM A276 TYPE 316	ASTM A276 TYPE 304L	ASTM A276 TYPE 316L
9.	EYE BOLT	CARBON STEEL	CARBON STEEL	CARBON STEEL	CARBON STEEL	CARBON STEEL

NOTE: The above data is subject to change without notice due to our continuing product improvement program.



CAST STEEL DUAL PLATE CHECK VALVES (DOUBLE FLANGE TYPE), API 594

TRIM MATERIAL COMBINATION (ON REQUEST)

Trim No.	Seat Ring Face	Wedge Seat Face	Stem	Backseat Bush	Lantern Ring
1	F6a/13%Cr.	F6a/13%Cr.	F6a/AISI410	F6a/AISI410	F6a/AISI410
2	F304	F304	F304/AISI304	F304/AISI304	F304/AISI304
5	STELLITE	STELLITE	F6a/AISI410	F6a/AISI410	F6a/AISI410
8	STELLITE	F6a/13%Cr.	F6a/AISI410	F6a/AISI410	F6a/AISI410
9	MONEL	MONEL	MONEL	MONEL	MONEL
10	F316	F316	F316/AIS1316	F316/AIS1316	F316/AIS1316
12	316+STELLITE	316	F316/AIS1316	F316/AIS1316	F316/AIS1316
13	ALLOY 20	ALLOY 20	ALLOY 20	ALLOY 20	ALLOY 20

NOTE: Other Trim Combination of API 600 Can Be Provided on Request.

DIMENSIONAL DATA CLASS-150

•All dimensions in mm

SIZE DN	50	65	80	100	150	200	250	300	350	400	450	500	600	700	900
L	60	67	73	73	98	127	146	181	184	191	203	219	222	305	368
∅C	50	65	68	100	150	200	250	300	350	400	450	500	600	700	900
∅D	150	180	190	230	280	345	405	485	535	595	635	700	815	837	1057
∅dk	92	104.6	127	157.4	216	269.7	324	381	412.8	470	533.5	584.2	692.2	762	972
k	120.7	139.7	152.4	190.5	241.3	298.5	361.9	431.8	476.2	539.7	577.8	635	749.3	795.3	1009.7
n	4	4	4	8	8	8	12	12	12	16	16	20	20	40	44
∅d	19.1	19.1	19.1	19.1	22.3	22.3	25.4	25.4	28.4	28.4	31.8	31.8	35	22.3	25.4
Aprox. Wt. [▲]	4.1	8.4	17.9	31.2	43.35	78.9	126.7	170	190	221	243	361	572	866	1577.2

DIMENSIONAL DATA CLASS-300

SIZE DN	50	65	80	100	150	200	250	300	350	400	450	500	600	700	900
L	60	67	73	73	98	127	146	181	222	232	264	292	318	292	330
∅C	50	65	68	100	150	200	250	300	350	400	450	500	600	700	900
∅D	165	190	210	255	320	380	445	520	585	650	710	775	915	1270	1500
∅dk	92	104.6	127	157.4	216	269.7	324	381	412.8	470	533.5	584.2	692.2	-	-
k	127	149.3	168.1	200.1	269.7	330.2	387.3	450.8	514.3	571.5	628.6	685.8	812.8	-	-
n	8	8	8	8	12	12	16	16	20	20	24	24	24	-	-
∅d	19.1	22.3	22.3	22.3	22.3	25.4	28.4	31.8	31.8	35	35	35	41.1	-	-
Aprox. Wt. [▲]	11.7	14.48	19.2	28.4	33	80	144.6	186	202.1	235	285	395	603	-	-

NOTE: The above data is subject to change without notice due to our continuing product improvement program.
Flanges above 24" as per ASME B16.47 series A or B.
Size above 24" details provided on order placement.

TEST PRESSURES

CLASS	SHELL TEST (HYDROSTATIC)		SHELL TEST (HYDROSTATIC)	
150	30 Bar	435 Psi g	22 Bar	319 Psi g
300	76 Bar	1102 Psi g	55 Bar	780 Psi g



CAST STEEL WAFER TYPE CHECK VALVE

CLASS RATING

PN-16

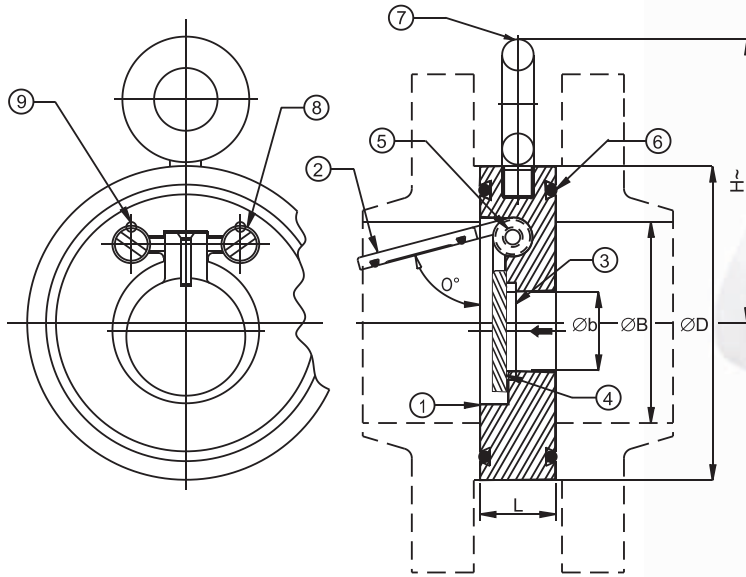

• All dimensions in mm

STANDARD MATERIAL COMBINATION

P.NO.	DESCRIPTION	MATERIALS	SPECIFICATIONS
1	BODY	CARBON STEEL	ASTM A 216:98 Gr. WCB
2	FLAP	CARBON STEEL	ASTM A 216:98 Gr. WCB
3	BODY SEAT RING	S.S.	ASTM A 276:04 T410
4	'O' RING	EPDM	-----
5	HINGE PIN	S.S.	ASTM A 276:04 T410 OR ITS EQUIVALENT
6	'O' RING	EPDM	-----
7	EYE BOLT	CARBON STEEL	-----
8	LOCKING PLUG	S.S.	ASTM A 276:04 T410 OR ITS EQUIVALENT
9	LOCKING PIN	S.S.	ASTM A 276:04 T410 OR ITS EQUIVALENT

DIMENSIONAL DATA

NPS	50	65	80	100	125	150	200	250	300
L	19	19	19	19	19	19	28.6	28.6	38.1
H	81	87	97	113	129	140	175	208	232
Øb	30	37	48	71	94.5	113	150	194	228
ØD	95	107	126	158	190	210.5	266	331.5	379
ØB	52.5	62.7	77.9	102.3	128.2	154.1	202.7	254.5	304.9
O°	50	60	68	60	64	63	67	65	71
Aprox. Wt. ▲	1.65	2.25	4.1	5.05	7	9.8	16	22	-----

TEST PRESSURES

NOMINAL PRESSURE ACCORDING TO CLASS DESIGNATION	SHELL TEST (HYDROSTATIC)	SEAT (HYDROSTATIC)
PN-16	2.4 Mpa (Hyd.)	1.76 Mpa (Hyd.)

NOTE: The above data is subject to change without notice due to our continuing product improvement program.



LEADER BUTTERFLY VALVE-BS 5155 / API 609 Category-A

SPECIFICATIONS

WAFER TYPE, WITH & WITHOUT LUGS, MOULDED / REPLACEABLE LINER, SUITABLE FOR CLAMPING BETWEEN FLANGES AS PER ANSI B16.5, CL-150

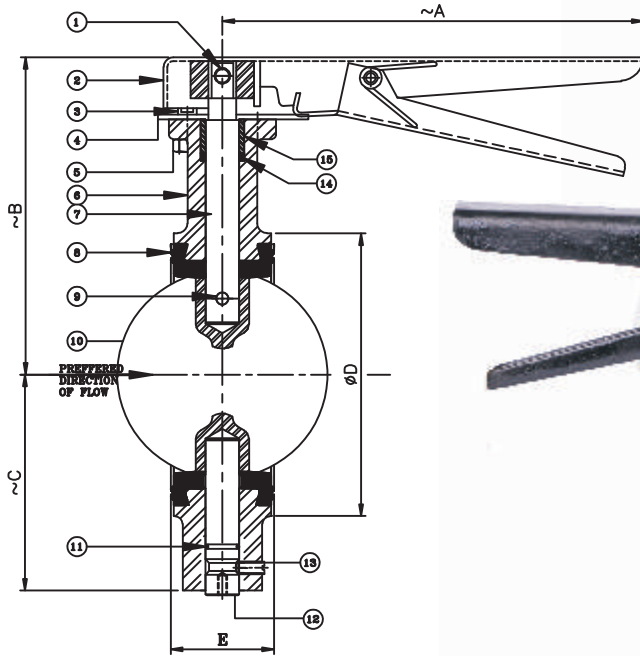

STANDARD MATERIAL COMBINATION

P.NO.	DESCRIPTION	MATERIALS	SPECIFICATIONS
1.	PIN	STEEL	HARDENED
2.	HANDLE (1½ to 6)	M.S. SHEET	IS 2062 Gr.B
	HANDLE (8" to 12")	M.I. (OR) C.S. (OR) NODULAR IRON	ASTMA 338/ASTMA 216 Gr.WCB OR B.S.2789 Gr.500/7
3.	SPRING WASHER	CARBON STEEL	-----
4.	COVER PLATE	M.S. SHEET	IS 2062 Gr. B
5.	NUTS & BOLTS	CARBON STEEL/ALLOY STEEL	BS 4190/ASTM A194 Gr. 2H
		CARBON STEEL/H.T. STEEL	BS 4190/ASTM A193 Gr.B7
6.	BODY	C.S.	ASTM A 216 Gr WCB
7.	UPPER STEM	S.S.	ASTM A 276 TYPE 410 OR ITS EQ.
8.	REPLACEBLE LINER	BUNA-N/EPDM	SHORE HARDNESS 70° ± 4
9.	TAPER PIN	STEEL	HARDENED
10.	DISC	C.S./S.S./AL. BRONZE/S.G.IRON	WCB/ ASTM 351 Gr.CF8/BSEN 1982/BS 2789 Gr.500/7
11.	O'RING	BUNA-N/EPDM	SHORE HARNNESS 60° ± 4
12.	LOWER STEM	S.S.	ASTM A276 TYPE 410 OR ITS EQ.
13.	GRUB SCREW	M.S.	-----
14.	WASHER	BUNA-N/EPDM	SHORE HARDNESS 60°±4
15.	BUSHING	HEAVY DUTY CORROSION RESISTANT TO ABSORB SIDE THRUST	



LEADER BUTTERFLY VALVE-BS 5155 / API 609 Category-A

SPECIFICATIONS

WAFER TYPE, WITH & WITHOUT LUGS, MOULDED / REPLACEABLE LINER, SUITABLE FOR CLAMPING BETWEEN FLANGES AS PER ANSI B16.5, CL-150

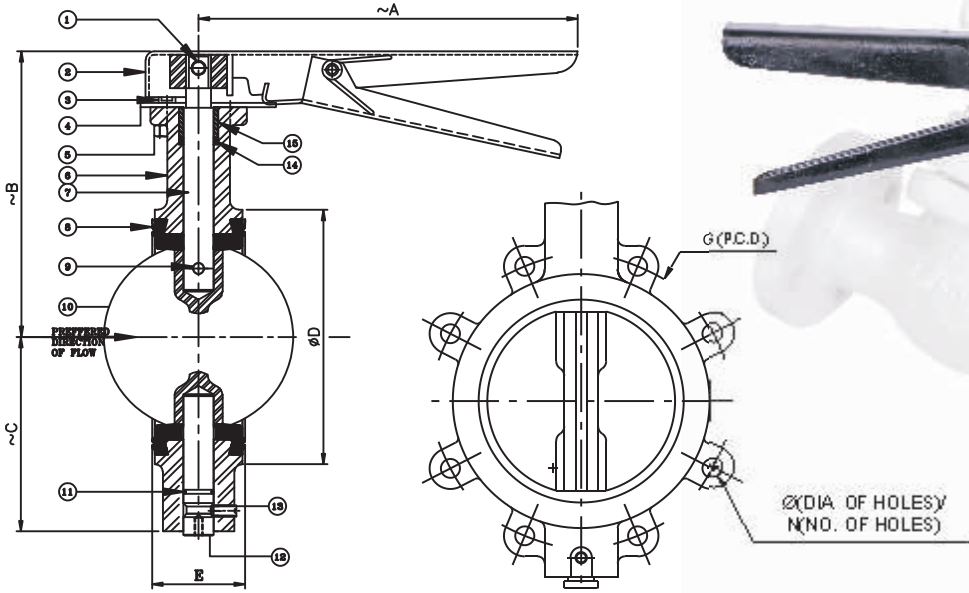

• All dimensions in mm

DIMENSIONAL DATA												
DN NPS	40 1 1/2"	50 2"	65 2 1/2"	80 3"	100 4"	125 5"	150 6"	200 8"	250 10"	300 12"	350* 14"	400* 16"
A	260	260	260	260	260	260	260	356	406	406		
B	120	133	150	153	210	200	237	235	290	330		
C	64	75	96	100	120	140	147	178	214	260	281	315
E	33 ±1	43 ±1	46 ±1	46 ±1	52 ±1	56 ±1	56 ±1	60 ±2	68 ±2	78 ±2	92 ±2	102 ±2
FØ	15.8	19	19	19	19	22.3	22.3	22.3	25.4	25.4	28.6	28.6
G(P.C.D)	98.5	120.6	139.7	152.4	190.5	215.9	241.3	298.4	361.9	431.8	476.2	539.8
I	----	----	----	----	----	----	240	240	290	330	340	412
JØ	----	----	----	----	----	----	200	200	250	250	300	500
N	4	4	4	4	8	8	8	8	12	12	20	20
ACTUATOR MODEL	----	----	----	----	----	----	----	----	----	----	PAC-01A	PAC-02A
Aprox. Wt. ▲	4.5	5.2	6.2	6.8	9.4	11.9	13.4	18.2	31.1	46.2		

NOTE: The above data is subject to change without notice due to our continuing product improvement program. (▲WEIGHT GIVEN IN KGS)
*For Gear Operated Valves

NOMINAL PRESSURE ACCORDING TO PN OR CLASS DESIGNATIONS	END DETAILS	TEST PRESSURES	
		BODY TEST (HYDROSTATIC)	SEAT TEST (HYDROSTATIC)
PN-10	SUITABLE FOR CLOMPING BETWEEN FLANGES AS PER ANSI B16.5 CL-150	15 bar (HYD)	11 bar (HYD)
PN-16	SUITABLE FOR CLOMPING BETWEEN FLANGES AS PER ANSI B16.5 CL-150	24 bar (HYD)	17.6 bar (HYD)



PRESSURE TEMPERATURE RATINGS

PRESSURE TEMPERATURE RATINGS TO ANSI B16:34, CL-150

TEMPERATURE °F	Working Pressure (Psi g)										
	WCB(1)	LCB(2)	WC1(3,4)	WC6(4,5)	WC9(4,5)	C5(4)	C12(4)	CF8(6)	CF8M(6)	CF3(7)	CF3M(6)
-20 to 100	285	265	265	290	290	290	290	275	275	275	275
200	260	255	255	260	260	260	260	230	235	230	235
300	230	230	230	230	230	230	230	205	215	205	215
400	200	200	200	200	200	200	200	190	195	190	195
500	170	170	170	170	170	170	170	170	170	170	170
600	140	140	140	140	140	140	140	140	140	140	140
650	125	125	125	125	125	125	125	125	125	125	125
700	110	110	110	110	110	110	110	110	110	110	110
750	95	95	95	95	95	95	95	95	95	95	95
800	80	80	80	80	80	80	80	80	80	80	80
850	65	65	65	65	65	65	65	65	65	65	65
900	50	50	50	50	50	50	50	50	50	50	50
950	35	35	35	35	35	35	35	35	35	35	35
1000	20	20	20	20	20	20	20	20	20	20	20
1050				20 (a)	20 (a)	20 (a)	20 (a)	20 (a)	20 (a)	20 (a)	20 (a)
1100				20 (a)	20 (a)	20 (a)	20 (a)	20 (a)	20 (a)	20 (a)	20 (a)
1150				20 (a)	20 (a)	20 (a)	20 (a)	20 (a)	20 (a)	20 (a)	20 (a)
1200				15 (a)	15 (a)	15 (a)	20 (a)	20 (a)	20 (a)	20 (a)	20 (a)
1250								20 (a)	20 (a)	20 (a)	20 (a)
1300								20 (a)	20 (a)	20 (a)	20 (a)
1350								20 (a)	20 (a)	20 (a)	20 (a)
1400								20 (a)	20 (a)	20 (a)	20 (a)
1450								20 (a)	20 (a)	20 (a)	20 (a)
1500								15 (a)	15 (a)	15 (a)	15 (a)

NOTES RELATED TO PRESSURE TEMP. RATINGS.
 (1) Permissible, but not recommended for prolonged use above 800°F.
 (2) Not to be used over 650°F.
 (3) Permissible, but not recommended for prolonged use above 875°F.
 (4) Use normalised and tempered material only.
 (5) Not to be used over 1100°F.
 (6) At temperature over 1000°F, use only when the carbon content is 0.04% or higher.
 (7) Not to be used over 800°F.

Note: (a) For welding ends valves only.

PRESSURE TEMPERATURE RATINGS TO ANSI B16:34, CL-300

TEMPERATURE °F	Working Pressure (Psi g)										
	WCB(1)	LCB(2)	WC1(3,4)	WC6(4,5)	WC9(4,5)	C5(4)	C12(4)	CF8(6)	CF8M(6)	CF3(7)	CF3M(6)
-20 to 100	740	695	695	750	750	750	750	720	720	720	720
200	680	660	660	750	750	750	750	600	620	600	620
300	655	640	640	720	730	730	730	540	560	540	560
400	635	615	615	695	705	705	705	495	515	495	515
500	605	585	585	665	665	665	665	465	480	465	480
600	570	550	550	605	605	605	605	440	450	440	450
650	550	535	535	590	590	590	590	430	440	430	440
700	530	510	510	570	570	570	570	420	435	420	435
750	505	475	475	530	530	530	530	415	425	415	425
800	410	390	390	510	510	510	510	405	420	405	420
850	320	300	300	485	485	485	485	395	420	395	420
900	230	200	200	450	450	375	450	390	415	390	415
950	135	135	135	320	385	275	375	380	385	380	385
1000	85	85	85	215	265	200	255	355	365	355	365
1050				145	175	145	170	225	160	255	160
1100				95	110	100	115	255	305	255	305
1150				65	70	60	75	205	235	205	235
1200				40	40	35	50	165	185	165	185
1250								135	145	135	145
1300								115	115	115	115
1350								95	95	95	95
1400								75	75	75	75
1450								60	60	60	60
1500								40	40	40	40

NOTES RELATED TO PRESSURE TEMP. RATINGS.
 (1) Permissible, but not recommended for prolonged use above 800°F.
 (2) Not to be used over 650°F.
 (3) Permissible, but not recommended for prolonged use above 875°F.
 (4) Use normalised and tempered material only.
 (5) Not to be used over 1100°F.
 (6) At temperature over 1000°F, use only when the carbon content is 0.04% or higher.
 (7) Not to be used over 800°F.



PRESSURE TEMPERATURE RATINGS

PRESSURE TEMPERATURE RATINGS TO ANSI B16:34, CL-600

TEMPERATURE °F	Working Pressure (Psi g)										
	WCB(1)	LCB(2)	WC1(3,4)	WC6(4,5)	WC9(4,5)	C5(4)	C12(4)	CF8(6)	CF8M(6)	CF3(7)	CF3M(6)
-20 to 100	1480	1395	1395	1500	1500	1500	1500	1440	1440	1440	1440
200	1360	1320	1320	1500	1500	1500	1500	1200	1240	1200	1240
300	1310	1275	1275	1445	1445	1455	1445	1075	1120	1075	1120
400	1265	1230	1230	1385	1410	1410	1410	995	1025	995	1025
500	1205	1175	1175	1330	1330	1330	1330	930	955	930	955
600	1135	1105	1105	1210	1210	1210	1210	885	900	885	900
650	1100	1065	1065	1175	1175	1175	1175	865	885	865	885
700	1060	1025	1025	1135	1135	1135	1135	845	870	845	870
750	1015	955	955	1065	1065	1065	1065	825	855	825	855
800	825	780	780	1015	1015	1015	1015	810	845	810	845
850	640	595	595	975	975	975	975	790	835	790	835
900	460	405	405	900	900	745	900	780	830	780	830
950	275	275	275	640	755	550	755	765	775	765	775
1000	170	170	170	430	535	400	505	710	725	710	725
1050				290	350	290	345	650	720	650	720
1100				190	220	200	225	515	610	515	610
1150				130	135	125	150	410	475	400	475
1200				80	80	70	105	330	370	310	370
1250								265	295	265	295
1300								225	235	225	235
1350								185	190	185	190
1400								150	150	150	150
1450								115	115	115	115
1500								85	85	85	85

- NOTES RELATED TO PRESSURE TEMP. RATINGS.**
- (1) Permissible, but not recommended for prolonged use above 800°F.
 - (2) Not to be used over 650°F.
 - (3) Permissible, but not recommended for prolonged use above 875°F.
 - (4) Use normalised and tempered material only.
 - (5) Not to be used over 1100°F.
 - (6) At temperature over 1000°F, use only when the carbon content is 0.04% or higher.
 - (7) Not to be used over 800°F.

PRESSURE TEMPERATURE RATINGS TO ANSI B16:34, CL-900

TEMPERATURE °F	Working Pressure (Psi g)										
	WCB(1)	LCB(2)	WC1(3,4)	WC6(4,5)	WC9(4,5)	C5(4)	C12(4)	CF8(6)	CF8M(6)	CF3(7)	CF3M(6)
-20 to 100	2220	2090	2090	2250	2250	2250	2250	2160	2160	2160	2160
200	2035	1980	1980	2250	2250	2250	2250	1800	1860	1800	1860
300	1965	1915	1915	2165	2185	2185	2185	1615	1680	1615	1680
400	1900	1845	1845	2080	2115	2115	2115	1490	1540	1490	1540
500	1810	1760	1760	1995	1995	1995	1995	1395	1435	1395	1435
600	1705	1655	1655	1815	1815	1815	1815	1325	1355	1325	1355
650	1650	1600	1600	1765	1765	1765	1765	1295	1325	1295	1325
700	1590	1535	1535	1705	1705	1705	1705	1265	1305	1265	1305
750	1520	1430	1430	1595	1595	1595	1595	1240	1280	1240	1280
800	1235	1175	1175	1525	1525	1525	1525	1215	1265	1215	1265
850	955	895	895	1460	1460	1460	1460	1190	1255	1190	1255
900	690	605	605	1350	1350	1120	1350	1165	1245	1165	1245
950	410	410	410	955	1160	825	1130	1145	1160	1145	1160
1000	255	255	255	650	800	595	760	1065	1090	1065	1090
1050				430	525	430	515	975	1080	975	1080
1100				290	330	300	340	770	915	770	915
1150				195	205	185	225	615	710	615	710
1200				125	125	105	155	495	555	495	555
1250								400	440	400	440
1300								340	350	340	350
1350								280	290	280	290
1400								225	225	225	225
1450								175	175	175	175
1500								125	125	125	125

- NOTES RELATED TO PRESSURE TEMP. RATINGS.**
- (1) Permissible, but not recommended for prolonged use above 800°F.
 - (2) Not to be used over 650°F.
 - (3) Permissible, but not recommended for prolonged use above 875°F.
 - (4) Use normalised and tempered material only.
 - (5) Not to be used over 1100°F.
 - (6) At temperature over 1000°F, use only when the carbon content is 0.04% or higher.
 - (7) Not to be used over 800°F.



PRESSURE TEMPERATURE RATINGS

PRESSURE TEMPERATURE RATINGS TO ANSI B16:34, CL-1500

TEMPERATURE °F	Working Pressure (Psi g)										
	WCB(1)	LCB(2)	WC1(3,4)	WC6(4,5)	WC9(4,5)	C5(4)	C12(4)	CF8 (6)	CF8M (6)	CF3 (7)	CF3M (6)
-20 to 100	3705	3480	3480	3750	3750	3750	3750	3600	3600	3600	3600
200	3395	3300	3300	3750	3750	3750	3750	3000	3095	3000	3095
300	3270	3190	3190	3610	3640	3640	3640	2690	2795	2690	2795
400	3170	3075	3075	3465	3530	3530	3530	2485	2570	2485	2570
500	3015	2930	2930	3325	3325	3325	3325	2330	2390	2330	2390
600	2840	2755	2755	3025	3025	3025	3025	2210	2255	2210	2255
650	2745	2665	2665	2940	2940	2940	2940	2160	2210	2160	2210
700	2665	2560	2560	2840	2840	2840	2840	2110	2170	2110	2170
750	2535	2385	2285	2660	2660	2660	2660	2065	2135	2065	2135
800	2055	1955	1955	2540	2540	2540	2540	2030	2110	2030	2110
850	1595	1490	1490	2435	2435	2435	2435	1980	2090	1980	2090
900	1150	1010	1010	2245	2245	1870	2245	1945	2075	1945	2075
950	685	685	685	1595	1930	1370	1885	1910	1930	1910	1930
1000	430	430	430	1080	1335	995	1270	1770	1820	1770	1820
1050				720	875	720	855	1630	1800	1630	1800
1100				480	550	495	565	1285	1525	1285	1525
1150				325	345	310	375	1030	1185	1030	1185
1200				205	205	170	255	825	925	825	925
1250								670	735	670	735
1300								565	585	565	585
1350								465	480	465	480
1400								380	380	380	380
1450								290	290	290	290
1500								205	205	205	205

NOTES RELATED TO PRESSURE TEMP. RATINGS.
(1) Permissible, but not recommended for prolonged use above 800°F.
(2) Not to be used over 650°F.
(3) Permissible, but not recommended for prolonged use above 875°F.
(4) Use normalised and tempered material only.
(5) Not to be used over 1100°F.
(6) At temperature over 1000°F, use only when the carbon content is 0.04% or higher.
(7) Not to be used over 800°F.

PRESSURE TEMPERATURE RATINGS TO ANSI B16:34, CL-2500

TEMPERATURE °F	Working Pressure (Psi g)										
	WCB(1)	LCB(2)	WC1(3,4)	WC6(4,5)	WC9(4,5)	C5(4)	C12(4)	CF8(6)	CF8M(6)	CF3(7)	CF3M(6)
-20 to 100	6170	5805	5805	6250	6250	6250	6250	6000	6000	6000	6000
200	5655	5505	5505	6250	6250	6250	6250	5000	5160	5000	5160
300	5450	5315	5315	6015	6070	6070	6070	4480	4660	4480	4660
400	5280	5125	5125	5775	5880	5880	5880	4140	4280	4140	4280
500	5025	4885	4885	5540	5540	5540	5540	3880	3980	3880	3980
600	4730	4595	4595	5040	5040	5040	5040	3680	3760	3680	3760
650	4575	4440	4440	4905	4905	4905	4905	3600	3680	3600	3680
700	4425	4270	4270	4730	4730	4730	4730	3520	3620	3520	3620
750	4230	3970	3970	4430	4430	4430	4430	3440	3560	3440	3560
800	3430	3255	3255	4230	4230	4230	4230	3380	3520	3380	3520
850	2655	2485	2485	4060	4060	4060	4060	3300	3480	3300	3480
900	1915	1685	1685	3745	3745	3115	3745	3240	3460	3240	3460
950	1145	1145	1145	2655	3220	2285	3145	3180	3220	3180	3220
1000	715	715	715	1800	2230	1655	2115	2950	3030	2950	3030
1050				1200	1455	1200	1430	2715	3000	2715	3000
1100				800	915	830	945	2145	2545	2145	2545
1150				545	570	515	630	1715	1970	1715	1970
1200				345	345	285	430	1370	1545	1370	1545
1250								1115	1230	1115	1230
1300								945	970	945	970
1350								770	800	770	800
1400								630	630	630	630
1450								485	485	485	485
1500								345	345	345	345

NOTES RELATED TO PRESSURE TEMP. RATINGS.
(1) Permissible, but not recommended for prolonged use above 800°F.
(2) Not to be used over 650°F.
(3) Permissible, but not recommended for prolonged use above 875°F.
(4) Use normalised and tempered material only.
(5) Not to be used over 1100°F.
(6) At temperature over 1000°F, use only when the carbon content is 0.04% or higher.
(7) Not to be used over 800°F.







Integrated Solutions For Industrial Valve

www.leadervalves.com







A series of horizontal dotted lines for writing, spanning the width of the page.

